

3. EXPERIMENTAL

In the present work, an appropriate electrostatic precipitator (ESP) was designed and built. Its collection performance was investigated under laboratory conditions by varying operation parameters such as particle size, velocity and the applied voltage to determine proper condition for collection of soot particles. Then collection performance of the designed ESP was tested on site at the rubberwood combustion burner. Finally, the effect of dust loading on the collection efficiency of the designed ESP was investigated.

3.1 The Designed ESP

The ESP used in this work was a wire-cylinder type. It was designed so that it could fit into the passage that the smoke was introduced to the smoking room. The collecting electrode was made of a 76-mm-diameter stainless steel cylinder with a height of 245 mm as shown in Fig. 10. A 0.5-mm-diameter, and a 300-mm-long copper wire, used as a corona-discharge electrode, was held in the center of the cylinder. Polyvinylchloride rings at both ends of the cylinder was used to electrically separate the electrodes. The cylinder wall was used for collecting the particles.

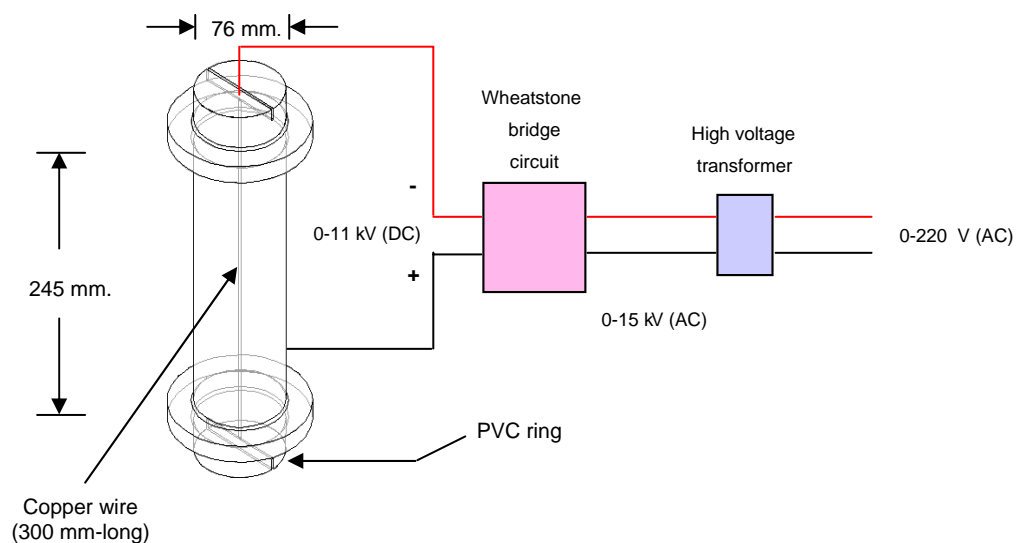
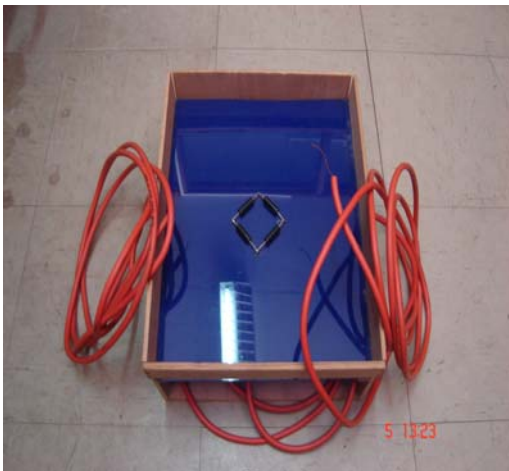

Figure 10. Model of an ESP design.



(a)



(b)



(c)

Figure 11. Photograph of the experimental devices for measuring the ESP efficiency. (a) The designed ESP. (b) The simple Wheatstone bridge circuit. (c) The high-voltage neon transformer.

The electrical components of the ESP consisted of

- A high-voltage neon transformer (Lecip, Ex230A15N) that could transform the input voltage from 0-220 V-rms(AC) to 0-15 kV(AC).
- A simple Wheatstone bridge circuit that rectified the AC current to ripple DC current. The maximum peak of the output ripple DC was about 11 kV. The high voltage diodes used in this circuit had a maximum voltage of 12 kV.

The simple direct current high-voltage circuit used in this work is shown in Fig. 12. The input voltage of 0-220 V-rms(AC) was step-up in ranging of 0-15 kV(AC) using a high-voltage transformer. It was then converted from 0-15 kV(AC) to 0-11 kV-peak (ripple) by a Wheatstone bridge circuit. The negative polar of the Wheatstone bridge circuit was applied to copper wire electrode and the positive polar was applied to the cylinder wall of the ESP.

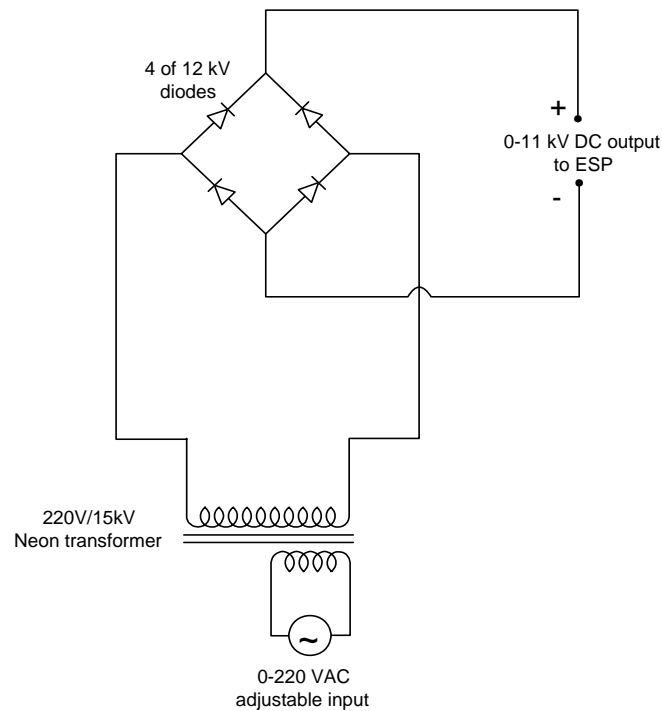

Figure 12. The direct current high-voltage circuit used in the experiment.

The output voltage was measured at discharge electrode (copper wire) using a High Voltage probe (Textronix, P6015A) and the signal is displayed on an Oscilloscope (Hitachi, V-252). The discharge current was measured between the collection electrode (cylinder wall) and ground using a Multimeter (Fluke, 83III).

3.2 The Laboratory Experiment

3.2.1 Experimental Setup

The schematically experimental setup for measuring the ESP efficiency in laboratory is shown in Fig. 13, and its photograph is shown in Fig. 14. Solid monodisperse polystyrene particles were prepared by dropping polystyrene latex (PSL) concentrate (Duke scientific) into volumetric bottle of 80 mL distilled water. After well mixing using ultrasonic bath for 15 minutes, the solution was atomized by a collision atomizer (Topas, ATM 225) to generate the aerosol. The water vapor and droplets in the aerosol stream were removed by introducing through a diffusion dryer. The diffusion dryer was constructed from polyvinylchloride (PCV) pipe with a diameter of 105 mm and a length of 850 mm. A 25-mm-diameter and a 850-mm-long porous PVC pipe was placed concentrically inside. Silica gel was used to fill up the annular space between the pipes.

The dried polystyrene aerosol particles were then neutralized by a 3-MBq Am-241 (Japan Radioisotope Association). The neutralized aerosol was diluted by mixing with clean air passing through an absolute filter (Cambridge Filter, 1GC-50-2-MCL).

To provide sufficient mixing between the air and particles before entering the ESP, a 50-mm-diameter and 350-mm-long clear acrylic tube and a 40-mm-diameter and 80-mm-long nozzle were used. The neutral aerosol particles were introduced to the ESP using vacuum pump (Gast, 0523-V4-G21DX). Flow rate was controlled by adjusting the needle valve and measured by an orifice meter and the corresponding U-tube manometer. The HEPA filter was used to prevent the aerosol particles to pass through the orifice meter during the experiment.

To evaluate the collection performance of the ESP, collection efficiency and pressure drop were measured. The collection efficiency was determined at various velocities and voltages using a laser particle counter (LPC: Royco, Portable 330B). Particle concentrations of the aerosol were sampled upstream and downstream of the ESP, respectively. The collection efficiency (η) can then be calculated from

$$\eta = 1 - \frac{C_{exit}}{C_{inlet}}$$

where C_{inlet} and C_{exit} are number concentrations of particles at the upstream and downstream of the ESP. The pressure drop across the ESP was measured by a differential pressure transducer (MSK, Baratron pressure transducer Type 223).

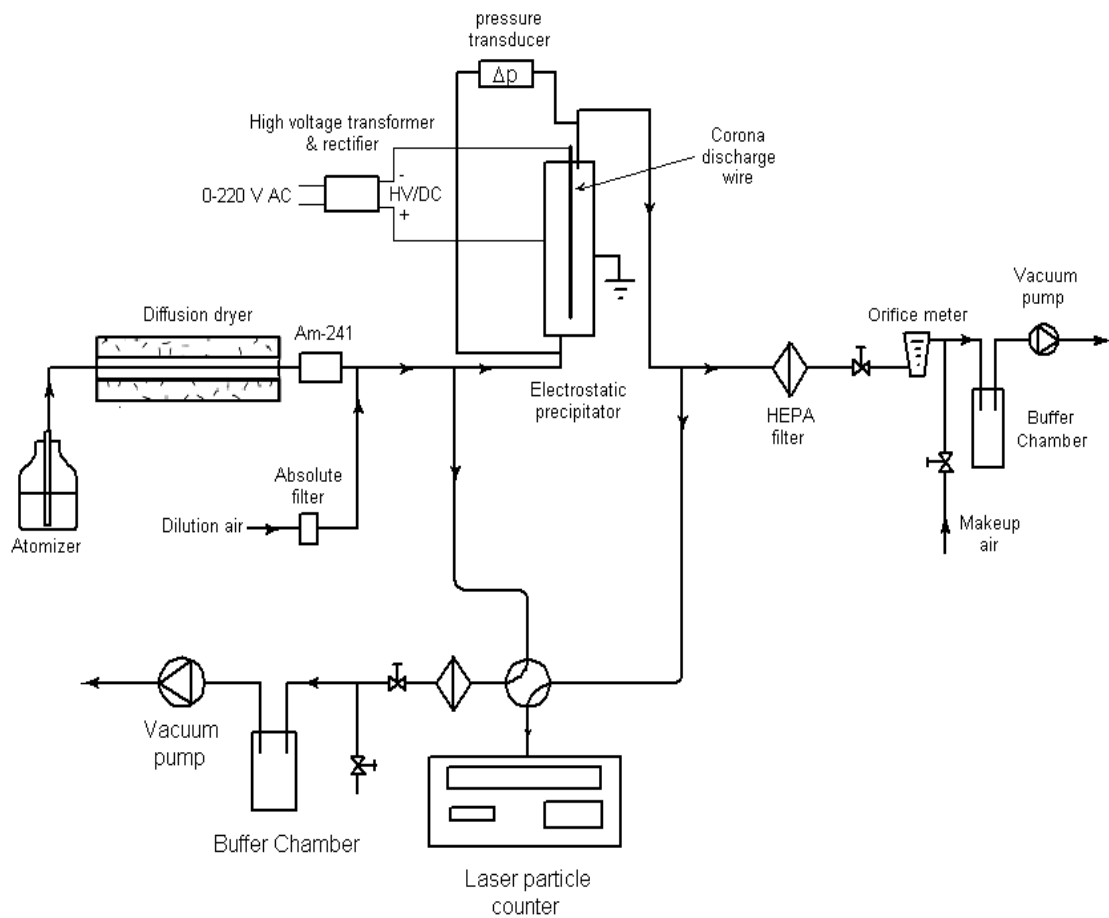

Figure 13. The schematic representation of the experimental setup for measuring the ESP efficiency in laboratory.



Figure 14. Photograph of the experimental setup for measuring the ESP efficiency in laboratory.

3.2.2 Experimental Parameters

The aerosol collection performance of the designed ESP was investigated by varying various basic operating parameters such as particle size, velocity and the applied voltage. To vary the particle sizes, the polystyrene latex (PSL) of 0.3, 0.5 and 1.0 micrometer were used to simulate the particle sizes of soot particles from wood combustion. The velocity was varied from about 1.0 cm/s to 15 cm/s by adjusting the flow rate using the needle valve. The applied voltage (input) was varied from 100 V-rms(AC) to 220 V-rms(AC) using a slide regulator (Chuan Hsin, SRV-10). Summary of the measured parameters is shown in Table 1.

Table 4. The measured operation parameters

Parameter	Range
Particle diameter, d_p (μm)	0.3, 0.5 and 1.0
Velocity, U (cm/s)	1-15
Applied voltage on wire, V_w (V-rms)	100-220

3.3 The On-Site Experiment

Study and comparison of the collection efficiency of the designed ESP from laboratory with the working condition at the rubberwood burner is essential. Influent of dust loading on the collection efficiency of the designed ESP can be the determined. Therefore, on-site experiment with the rubberwood burner to simulate the real working condition had been performed.

3.3.1 Experimental Setup

The schematic representation of the experimental setup for measuring the ESP efficiency on site test is shown in Fig. 15. The rubberwood burner was used to generate soot particles by continuously supplying the rubberwood. The soot

particles were then introduced to the ESP using a vacuum pump (Gast, 0523-V4-G21DX) and all experiments were carried out at 220 V-rms(AC) supply voltage.

The collection efficiency of the ESP was measured for 10 hours operation time of rubberwood burning on mass basis by using HEPA filters (Cambridge). Aerosol was sampled upstream and downstream of the ESP for 600 minutes at every 30 minutes of operation time. Sampling flow rate was set to be 20 L/min. The flow rate of aerosol in the ESP was then 20 L/min which was corresponding to the velocity of 7.4 cm/s. The applied voltage was set at the maximum value of 220 V-rms(AC). The filters were treated prior to use by placing in the desiccator at room temperature with a 50-60 % of relative humidity using a sodium dichromate solution as the controller for at least 24 hours. The filters were then weighted using 0.0001 g readability analytical balance (Mettler, AB204-S).

The weight of dust or collected particles on the ESP was measured at every 30 minutes of rubber wood burning using 0.01 g readability analytical balance (Mettler, PB3002) until 10 hours of operation time of rubber wood burning.

The collection efficiency and the loading of dust on the ESP were plotted as a function of particle concentration and operation times in terms of Cvt [kg/m^2] or the amount of dust that flows to the ESP per cross section, where C is the initial particles concentration, v is the velocity and t is the time.

The collection efficiency, based on total concentration (all sizes of particles), is evaluated from the mass different of HEPA filters upstream and downstream of the ESP can be defined by

$$\eta = 1 - \frac{C_{final}}{C_{initial}}$$

where $C_{initial}$ and C_{final} are the mass concentrations of particles upstream and downstream of the ESP, respectively.

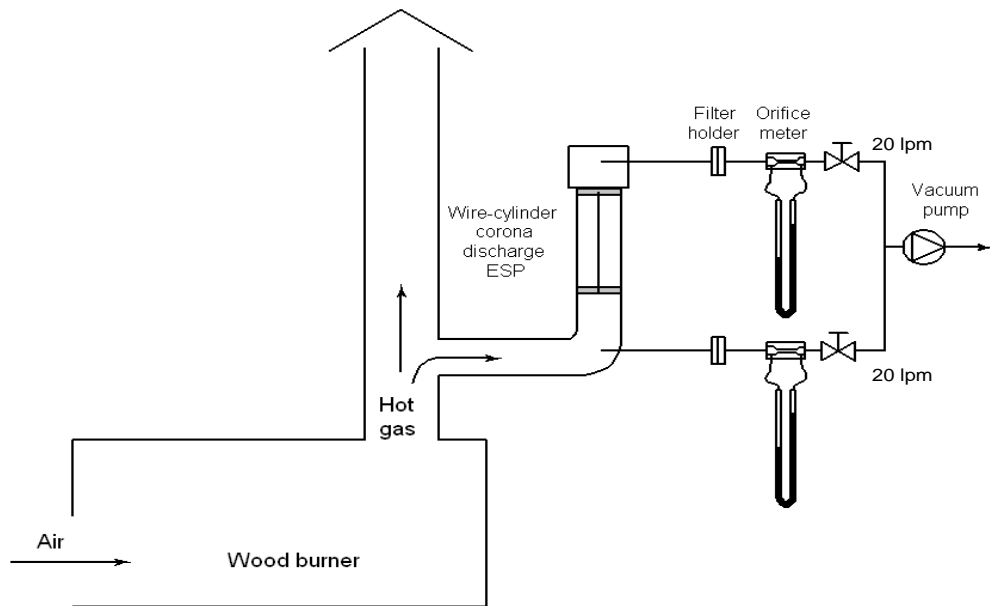

Figure 15. The schematic representation of the experimental setup for measuring the ESP efficiency on site test.



Figure 16. Photograph of the experimental setup for measuring the ESP efficiency on site.

3.3.2 Dust-Loading Experiment

The effect of dust loading was studied to investigate collection performance of the ESP to compare with the results from laboratory experiment.

Initially, the clean ESP was installed into the rubberwood combustion burner for 30 minutes at the flow rate of 20 L/min. The maximum input voltage of 220 V-rms(AC) was then applied to the ESP to effectively provide the loading of dust or collection of particles on the ESP. Finally, the collection efficiency of the dust-loaded ESP was measured and evaluated in laboratory to study the effect of dust loading on the ESP.

The collection efficiency of the dust-loaded ESP was investigated by setting up the experiment as in section 3.2.1. Since the MMAD of soot particles in the smoking room is nearly 1.0 micrometer so the PSL particle with 1.0 micrometer diameter was used to test and compare the collection efficiency of the ESP. The flow rate of the aerosol was varied from about 1.0 cm/s to 15 cm/s, adjusting the flow rate using the needle valve.

The discharge current of the dust-loaded ESP was measured between the collection electrode (cylinder wall) and ground using a Multi-meter (Fluke, 83III) as in section 3.1.