



**Effects of Salinity, Light intensity and Sediment on Growth, Pigments, Agar
production and Reproduction in *Gracilaria tenuistipitata* C.F. Chang & B.M. Xia
at Koh Yor, Songkhla Lagoon, Songkhla Province, Thailand.**

Chaloemphon Bunsom

**A Thesis Submitted in Partial Fulfillment of the Requirements for the Degree of
Master of Science in Botany
Prince of Songkla University**

2010

Copyright of Prince of Songkla University

Thesis Title Effects of salinity, light intensity and sediment on growth, pigments, agar production and reproduction in *Gracilaria tenuistipitata* C.F. Chang & B.M. Xia at Koh Yor, Songkhla lagoon, Songkhla Province, Thailand.

Author Mr. Chalophon Bunsom

Major Program Botany

Major Advisor:

.....
(Asst. Prof. Dr. Anchana Prathep)

Examining Committee:

.....Chairperson
(Dr. Sorawit Powtongsook)

.....
(Asst. Prof. Dr. Anchana Prathep)

.....
(Dr. Rapeeporn Ruangchuay)

The Graduate School, Prince of Songkla University, has approved this thesis as partial fulfillment of the requirements for the Master of Science Degree in Botany

.....
(Assoc. Prof. Dr. Krerckchai Thongnoo)
Dean of Graduate School

ชื่อวิทยานิพนธ์	ผลกระทบของความเค็ม ความเข้มของแสง และตะกอน ต่อการเจริญเติบโต รงควัตถุ การผลิตวุ้น และการสืบพันธุ์ ในสาหร่ายผมนาง <i>Gracilaria tenuistipitata</i> C.F. Chang & B.M. Xia บริเวณเกาะยอ ทะเลสาบสงขลา จังหวัดสงขลา ประเทศไทย
ผู้เขียน	นายเฉลิมพล บุญสม
สาขาวิชา	พฤกษศาสตร์
ปีการศึกษา	2552

บทคัดย่อ

สาหร่ายสีแดง *Gracilaria tenuistipitata* C.F. Chang & B.M. Xia พบการแพร่กระจายได้ทั่วไปในเขตร้อน สำหรับในประเทศไทยสามารถพบ *G. tenuistipitata* แพร่กระจายอยู่ทั่วไปในอ่าวปัตตานีและทะเลสาบสงขลา ซึ่ง ในปัจจุบันประชากร *G. tenuistipitata* ในทะเลสาบสงขลา ลดจำนวนลง จากการเปลี่ยนแปลงของ สภาพแวดล้อมและการพัฒนาพื้นที่รอบบริเวณทะเลสาบ จุดมุ่งหมายของงานวิจัยชิ้นนี้ คือ การศึกษาอิทธิพลของ ความเค็ม ความเข้มแสงและตะกอน ต่อ *G. tenuistipitata* จากทะเลสาบสงขลา โดยจัดชุดการทดลอง ภายใต้สภาวะที่แตกต่างกัน คือ ความเค็ม (0, 25 และ 33 ppt), ความเข้มแสง (150, 400, 700 และ 1,000 $\mu\text{mol photons m}^{-2} \text{s}^{-1}$) และปริมาณตะกอน (0, 0.67 และ 2.28 mg/L) จากการศึกษาพบว่า สาหร่ายได้รับอิทธิพลจากความเค็ม ความเข้มแสง และตะกอน อย่างมีนัยสำคัญ ($P < 0.05$) ค่ามวลชีวภาพดีที่สุดคือ 6.85 %WG ต่อวัน เจริญในสภาวะความเค็ม 25 ppt ที่ความเข้มแสง 700 $\mu\text{mol photons m}^{-2} \text{s}^{-1}$ และภาวะที่ไม่มีตะกอน สภาวะที่เหมาะสมในการผลิตวุ้น (24.80 %DW) พบในสภาวะความเค็ม 25 ppt ที่ความเข้มแสง 150-400 $\mu\text{mol photons m}^{-2} \text{s}^{-1}$ และภาวะที่ไม่มีตะกอน ส่วนปริมาณรงควัตถุสูงสุด พบ phycoerythrin ($0.841 \pm 0.04 \text{ mg g}^{-1} \text{ FW}$) และ phycocyanin ($0.341 \pm 0.05 \text{ mg g}^{-1} \text{ FW}$) ในสภาวะความเข้มแสง 150 $\mu\text{mol photons m}^{-2} \text{s}^{-1}$ และ chlorophyll a ($0.211 \pm 0.02 \text{ mg g}^{-1} \text{ FW}$) พบในสภาวะความเข้มแสง 700 $\mu\text{mol photons m}^{-2} \text{s}^{-1}$ นอกจากนี้ในการเลี้ยงระยะสั้น พบอัตราการสังเคราะห์ด้วยแสงสูงสุด ($161.33 \pm 32.64 \text{ mg O}_2 \text{ g d wt}^{-1} \text{ h}^{-1}$) พบในสภาวะความเค็ม 25 ppt ที่ความเข้มแสง 400 $\mu\text{mol photons m}^{-2} \text{s}^{-1}$ และภาวะที่ไม่มีตะกอน ส่วนอัตราการหายใจสูงสุด ($45.91 \pm 30.81 \text{ mg O}_2 \text{ g d wt}^{-1} \text{ h}^{-1}$) พบในสภาวะความเค็ม 25 ppt ที่ความเข้มแสง 150 $\mu\text{mol photons m}^{-2} \text{s}^{-1}$ และภาวะที่มีตะกอนเล็กน้อย ส่วนในการเลี้ยงระยะยาว พบอัตราการสังเคราะห์ด้วยแสงสูงสุด ($60.26 \pm 6.71 \text{ mg O}_2 \text{ g d wt}^{-1} \text{ h}^{-1}$) พบในสภาวะความเค็ม 25 ppt ที่ความเข้มแสง 700 $\mu\text{mol photons m}^{-2} \text{s}^{-1}$ และภาวะที่ไม่มี

ตะกอน ส่วนอัตราการหายใจสูงสุด ($43.48 \pm 25.07 \text{ mg O}_2 \text{ g d wt}^{-1} \text{ h}^{-1}$) พบในสภาวะความเค็ม 0 ppt ที่ความเข้มแสง $1,000 \text{ } \mu\text{mol photons m}^{-2} \text{ s}^{-1}$ และภาวะที่มีตะกอนสูง จากผลการศึกษาชี้ให้เห็นว่า *G. tenuistipitata* ได้รับผลกระทบ อย่างมากจากปัจจัยด้านความเค็มและความเข้มแสง

Thesis Title Effects of salinity, light intensity and sediment on growth, pigments, agar production and reproduction in *Gracilaria tenuistipitata* C.F. Chang & B.M. Xia at Koh Yor, Songkhla lagoon, Songkhla Province, Thailand.

Author Mr. Chalophon Bunsom

Major Program Botany

Academic Year 2009

Abstract

The red algae, *Gracilaria tenuistipitata* C.F. Chang & B.M. Xia widely distributes in the tropic. In Thailand, *G. tenuistipitata* is commonly found in Pattani Bay and Songkhla Lagoon. Nowadays the population of *Gracilaria* spp in Songkhla lagoon was declined because of the developments around the lagoon. The aim of this research is to study the effects of salinity, light intensity and sediment on *G. tenuistipitata*, which were collected from Songkhla Lagoon and tested in laboratory under different conditions; salinities (0, 25 and 33 ppt), light intensities (150, 400, 700 and 1,000 $\mu\text{mol photons m}^{-2}\text{s}^{-1}$) and sediment (0, 0.67 and 2.28 mg/L). The results showed that *G. tenuistipitata* were significantly influenced by salinity, light intensity and sediment ($P < 0.05$). The highest biomass was 6.85 %WG cultured in 25 ppt, 700 $\mu\text{mol photons m}^{-2}\text{s}^{-1}$ and no sediment. The best condition for the highest agar production (24.80 ± 2.96 %DW) was found in 25 ppt, 150-400 $\mu\text{mol photons m}^{-2}\text{s}^{-1}$ and no sediment. The highest of pigment contents; phycoerythrin (0.841 ± 0.04 mg g^{-1}FW) and phycocyanin (0.341 ± 0.05 mg g^{-1}FW) were found in 150 $\mu\text{mol photons m}^{-2}\text{s}^{-1}$ and chlorophyll *a* (0.211 ± 0.02 mg g^{-1}FW) was found in 700 $\mu\text{mol photons m}^{-2}\text{s}^{-1}$. In short period of cultivation, the highest photosynthesis rate was 161.33 ± 32.64 mg O_2 g d $\text{wt}^{-1}\text{h}^{-1}$ in 25 ppt, 400 $\mu\text{mol photons m}^{-2}\text{s}^{-1}$ and no sediment. The highest respiration rate (45.91 ± 30.81 mg O_2 g d $\text{wt}^{-1}\text{h}^{-1}$) were found in 25 ppt, 150 $\mu\text{mol photons m}^{-2}\text{s}^{-1}$ and low sediment. In long period of cultivation, the highest photosynthesis rate was

60.26±6.71 mg O₂ g d wt⁻¹h⁻¹ in 25 ppt, 700 μmol photons m⁻²s⁻¹ and no sediment. The highest respiration rate was 43.48±25.07 mg O₂ g d wt⁻¹h⁻¹ in 0 ppt, 1,000 μmol photons m⁻²s⁻¹ and high sediment. The results suggested that *G. tenuistipitata* were strongly affected by salinity and light intensity.

CONTENT

	Page
Content	viii
List of tables	x
List of figures	xii
Chapter 1	
Introduction	1
Review of literature	3
The characteristics of <i>Gracilaria tenuistipitata</i>	
C.F. Chang & B.M. Xia	3
The ecology of <i>Gracilaria tenuistipitata</i>	
C.F. Chang & B.M. Xia	4
The reproduction of <i>Gracilaria tenuistipitata</i>	
C.F. Chang & B.M. Xia	5
Biochemical of <i>Gracilaria tenuistipitata</i>	
C.F. Chang & B.M. Xia	7
Environmental Factors	7
Research question	21
Hypotheses	21
Objective	21
Chapter 2	
Materials and Methods	22
Study site	22
Methods	25
- Field study	25
- Laboratory study	26
Statistical analyses	30

CONTENT(Continued)

	Page	
Chapter 3	Results	32
	Environmental Parameters	32
	Population of <i>G. tenuistipitata</i>	38
	Morphology	39
	Biomass	43
	Pigment content	46
	Photosynthesis	52
	Respiration	56
	Agar	60
Chapter 4	Discussion	62
	Effect of environmental parameters at Koh Yor	62
	Effects of salinity	63
	Effects of Light	64
	Effects of sediment	65
Chapter 5	Conclusions	67
References		68
Appendix		74
Vitae		76

LIST OF TABLES

Table	Page
1. Summary of some studies on the effects of salinity, light intensity, temperature, turbidity and nutrients on <i>Gracilaria</i> sp.	8
2. Summary of physical and chemical parameters of the environmental parameters during January 2006 to December 2007 at Koh Yor.	32
3. The difference of mean biomass production of <i>G. tenuistipitata</i> in sediment, light intensity and salinity conditions.	43
4. Partial correlations coefficients of environmental parameters on biomass, pigment contents, photosynthesis, respiration and agar of <i>G. tenuistipitata</i> .	44
5. The difference of mean chlorophyll <i>a</i> content of <i>G. tenuistipitata</i> in sediment, light intensity and salinity conditions.	46
6. The difference of mean phycoerythrin content of <i>G. tenuistipitata</i> in sediment, light intensity and salinity conditions.	48
7. The difference of mean phycocyanin content of <i>G. tenuistipitata</i> in sediment, light intensity and salinity conditions.	50
8. The difference of mean the photosynthesis rates of <i>G. tenuistipitata</i> in sediment, light intensity and salinity conditions on short period cultivations.	53
9. The difference of mean the photosynthesis rates of <i>G. tenuistipitata</i> in sediment, light intensity and salinity conditions on long period cultivations.	53

LIST OF TABLES (Continued)

Table	Page
10. The difference of mean respiration of <i>G. tenuistipitata</i> in sediment, light intensity and salinity conditions on short period cultivations.	57
11. The difference of mean respiration of <i>G. tenuistipitata</i> in sediment, light intensity and salinity conditions on long period cultivations.	57
12. The difference of mean agar production of <i>G. tenuistipitata</i> in sediment, light intensity and salinity conditions.	60

LIST OF FIGURES

Figure	Page
1. The thallus of <i>Gracilaria tenuistipitata</i> C.F. Chang & B.M. Xia	4
2. Transection of main axis of <i>Gracilaria tenuistipitata</i> C.F. Chang & B.M. Xia	4
3. The cystocarp of <i>Gracilaria tenuistipitata</i> C.F. Chang & B.M. Xia	5
4. Transection of cystocarp of <i>Gracilaria tenuistipitata</i> C.F. Chang & B.M. Xia	6
5. The life cycle of <i>Gracilaria</i> (FAO/NACA, 1996)	6
6. Sampling sites at Koh Yor, Songkhla lagoon, Songkhla Province, Thailand (LP; Laemphor Temple, KP; Khokpeaw Temple, TY; Taiyor Temple, KB; Khaobor Temple).	23
7. Many substrates are found at coastlines such as artificial reef at Khokpeaw Temple (KP).	24
8. The sediment trap was used to trap suspended sediment for 24 hrs.	26
9. Flow chart showing experimental design in the laboratory.	27
10. The experiments were set up in laboratory, by manipulating salinity, light intensity and sediment.	28
11. Seasonal changes in air temperature from January 2006 to December 2007	33
12. Seasonal changes in water temperature from January 2006 to December 2007.	33
13. Seasonal changes in salinity from January 2006 to December 2007.	34
14. Seasonal changes in transparency from January 2006 to December 2007.	35

LIST OF FIGURES (Continued)

Figure	Page
15. Seasonal changes in light intensity from January 2006 to December 2007	36
16. Seasonal changes in sedimentation from January 2006 to December 2007.	37
17. Grain size of sediment at Koh Yor during April 2006 to January 2007.	37
18. Occurrence of <i>Gracilaria</i> spp. population compares with salinity at Koh Yor between January 2006 to December 2007	38
19. <i>G. tenuistipitata</i> after cultured under 150 $\mu\text{mol photons m}^{-2}\text{s}^{-1}$ of light intensity condition in each salinity and 3 levels of sediment for 20 days.	39
20. <i>G. tenuistipitata</i> after cultured under 400 $\mu\text{mol photons m}^{-2}\text{s}^{-1}$ of light intensity condition in each salinity and 3 levels of sediment for 20 days.	40
21. <i>G. tenuistipitata</i> after cultured under 700 $\mu\text{mol photons m}^{-2}\text{s}^{-1}$ of light intensity condition in each salinity and 3 levels of sediment for 20 days.	41
22. <i>G. tenuistipitata</i> after cultured under 1,000 $\mu\text{mol photons m}^{-2}\text{s}^{-1}$ of light intensity condition in each salinity and 3 levels of sediment for 20 days.	42
23. Mean biomass of <i>G. tenuistipitata</i> in each culturing after 20 days cultured.	45
24. Changes in chlorophyll <i>a</i> content of <i>G. tenuistipitata</i> when cultured under different salinity, light intensity and sediment conditions for 20 days.	47

LIST OF FIGURES (Continued)

Figure	Page
25. Changes in phycoerythrin content of <i>G. tenuistipitata</i> where cultured under different salinity, light intensity and sediment conditions for 20 days.	49
26. Changes in phycocyanin content of <i>G. tenuistipitata</i> when cultured under different salinity, light intensity and sediment conditions for 20 days.	51
27. Effect of salinity, light intensity and sediment on photosynthesis rates of <i>G. tenuistipitata</i> in short period culturing (3 days).	54
28. Effect of salinity, light intensity and sediment on photosynthesis rates of <i>G. tenuistipitata</i> in long period culturing (20 days).	55
29. Effect of salinity, light intensity and sediment on respiration of <i>G. tenuistipitata</i> in short period culturing (3 days)	58
30. Effect of salinity, light intensity and sediment on respiration of <i>G. tenuistipitata</i> in long period culturing (20 days).	59
31. Mean Agar production of <i>G. tenuistipitata</i> in each culturing after 20 days cultured.	61

CHAPTER 1

INTRODUCTION

Macroalgae or seaweed have been used as vegetables, materials for medicinal or pharmaceutical use, phycocolloid sources, raw materials for feed and fertilizer (Armisen, 1995; Araño *et al.*, 2000; McHugh, 2003). *Gracilaria* spp. (Rhodophyta) are one of commercial seaweeds which have high economic values. At present, *Gracilaria* spp. are the most important raw materials for producing agar and easy to farm. In China, the average productivity of *Gracilaria* spp. was 3,340 tones and output in the agar production reached 260 tones in 1993 (FAO/NACA, 1996). Wet and dry *Gracilaria* productions in Thailand, were 80 and 20 tons per year respectively, but the commercial requirement was more than 2,400 tons (Department of Fisheries, 2005).

Songkhla lagoon, a mesotrophic lagoon, is the largest natural [lagoon](#) of [Thailand](#). There are varieties and abundance in aquatic animals and plants. Its rich resources have supported well to fishery and way of life of people around. Furthermore, *Gracilaria* spp. are known to be an important resource in Songkhla lagoon, especially at Koh Yor. Most of the commercial crop comes from the wild or planted beds in the lagoon. However, population of *Gracilaria* spp. is declined because of development around and above the lagoon; this has dramatically changed physical factors such as salinity and turbidity (Angsupanich and Rakkheaw, 1997; Angsupanich and Kuwabara, 1999; Panapitukkul *et al.*, 2005).

The salinity is an important factor for photosynthesis, respiration, and growth of *Gracilaria* spp. (Israel *et al.*, 1999; Li-hon *et al.*, 2002). Lowered salinities often inhibit growth of seaweeds, vary branching patterns and promote changes in the chemical composition of seaweeds (Ekman *et al.*, 1999; Choi *et al.*, 2006).

Light intensity is also important for photosynthesis, and ultimately for all biological processes. The quality and quantity of light depend on such factors as depth, the number of particles in water (turbidity) and the amount of daily light in seasonal variation (Lobban *et al.*, 1985). Ability of seaweed to absorb light energy are

different, depends on quantity of pigment or density of photosynthetic units which able to tolerate and adapt for growing under light variation (Darley, 1982).

The adaptation is always important for the algae populations at all depths. Red algae are best adapted to vary of light. The pigment composition is increasing when increased depth or low light intensities which cause by chromatic adaptation (Beer and Levy, 1983; Carnicas *et al.*, 1999)

Increasing of sediment loads has been recognized as a major threat to marine biodiversity at a global scale. Changes in sedimentation have been problem for aquaculture, which have resulted from activities such as deforestation, agriculture, coastal development, construction, mining, drilling and dredging. Sediment is known to influence macroalgae community as well as the associated animals (Airoldi, 2003). Generally, organisms that rely upon sexual reproduction are more vulnerable than those using vegetative means, probably due to the lack of substrate stability and likelihood of smothering of new recruits (Airoldi, 2003; Chapman and Fletcher, 2002). In contrast, organisms with sediment trapping morphologies, opportunistic species as well as those with physical adaptation to sediment tend to do well in sediment-affected environments (Airodi, 2003 and Prathep *et al.*, 2003).

In this study, we test the effects of salinity, light intensity and sediment on growth, biomass, pigments content, photosynthesis rate, respiration rate, amount of agar and reproduction of *Gracilaria tenuistipitata* C.F. Chang & B.M. Xia. In addition, this is hope to bring back *G. tenuistipitata* cultivation to Songkhla lagoon by using this baseline information, which will provide an ideal condition for seaweed cultivation both in the lagoon and/or farming.

Review of literature

The characteristics of the genus *Gracilaria*

Classification of *Gracilaria* (Guiry and Guiry, 2010)

Phylum	Rhodophyta
Subphylum	Eurhodophytina
Class	Florideophyceae
Subclass	Rhodymeniophycidae
Order	Gracilariales
Family	Gracilariaceae
Genus	<i>Gracilaria</i>
Species	<i>Gracilaria tenuistipitata</i> C.F. Chang & B.M. Xia

The characteristic of *Gracilaria tenuistipitata* C.F. Chang & B.M. Xia

The dark-red thallus is thin, cylindrical, cartilaginous, solitary and growing from a small disc-like holdfast, 5-30 cm tall and 0.2-1.0 mm in diameter. The cylindrical branching is constructed at the base and tapering toward the tips. The algae have a tendency to be flattened or foliose with pseudoparenchymatous tissues that lack filamentous cells in mature vegetative thallus. The thallus are large thick walled cells 225-390 μm , with walls, 13-16 μm thick, in the centre, toward the surface considerably smaller, the cortex of 1-2 layers of rounded cells 10-20 μm diameter, with cuticle 10-13 μm . Unicellular hairs arise from enlarged peripheral cells that become multinucleate as they age (Lee, 1999; Lewmanomont and Ogawa, 1995; FAO/NACA, 1996) (Figure 1 and 2).



Figure 1. The thallus of *Gracilaria tenuistipitata* C.F. Chang & B.M. Xia



Figure 2. Transection of main axis of *Gracilaria tenuistipitata*
C.F. Chang & B.M. Xia

The ecology of *Gracilaria tenuistipitata* C.F. Chang & B.M. Xia

G. tenuistipitata is found growing on gravels and shells, broken stones, pebbles, polyethylene bags and fish cages, in sandy muddy areas of turbid water. It is exposed to air during extreme low tide and found in the sublittoral region of lower

salinity. In Thailand, this species is known to be abundant in Pattani Bay and Songkhla lagoon (Lewmanomont and Ogawa, 1995; FAO/NACA, 1996).

The reproduction of *Gracilaria tenuistipitata* C.F. Chang & B.M. Xia

Mature tetrasporophyte produces male gametophyte (n) or female gametophyte (n) from tetraspores. The male plants produce spermatia in antheridial pits over surface of thalli. The female plants form supporting cells from outer layer of medulla and develop into nutritive cells except for the carpogonium. After fertilization, female plant forms cystocarps, which prominently protrude, globes, rostrate, constricted at base and large 830-950 μm . Pericarp consisting of 8-10 layers of cells of which the outmost layer cells are round or ovoid, with a distinct cell wall (Figure 3 and 4) Cystocarps releases carpospores which round or ovoid in shape, 33-49 μm in diameter. The carpospores germinate to produce a parenchymatous disc and develop to tetrasporophyte (Figure 5) (Lee, 1999; FAO/NACA, 1996).

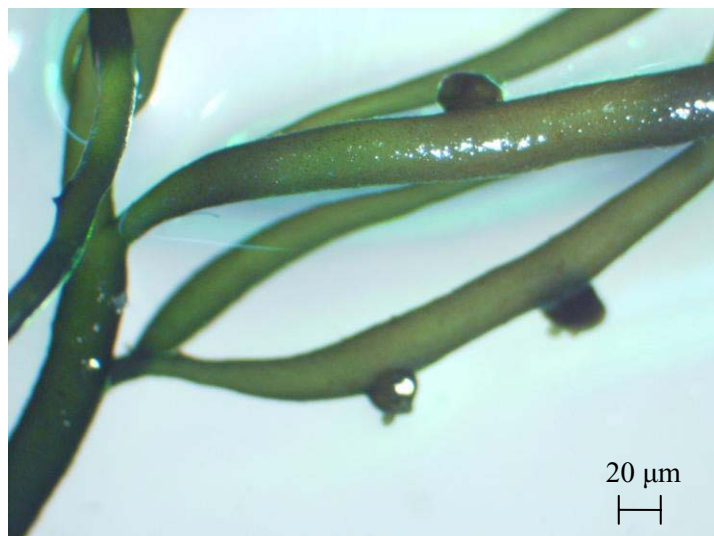

Figure 3. The cystocarp of *Gracilaria tenuistipitata* C.F. Chang & B.M. Xia

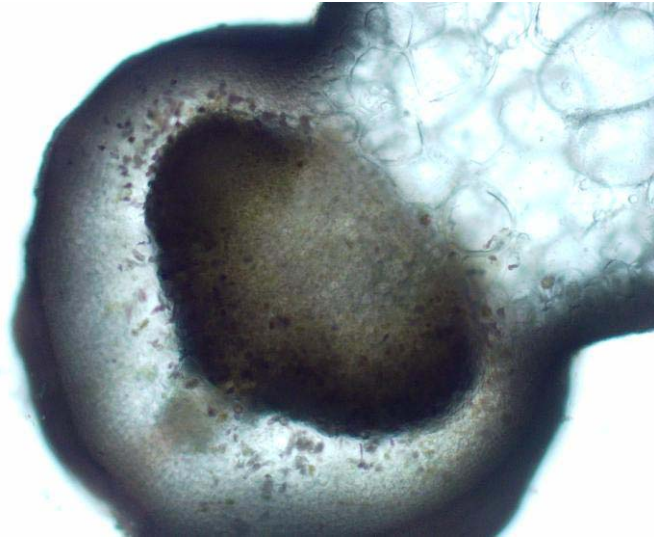

Figure 4. Transection of cystocarp of *Gracilaria tenuistipitata*
C.F. Chang & B.M. Xia

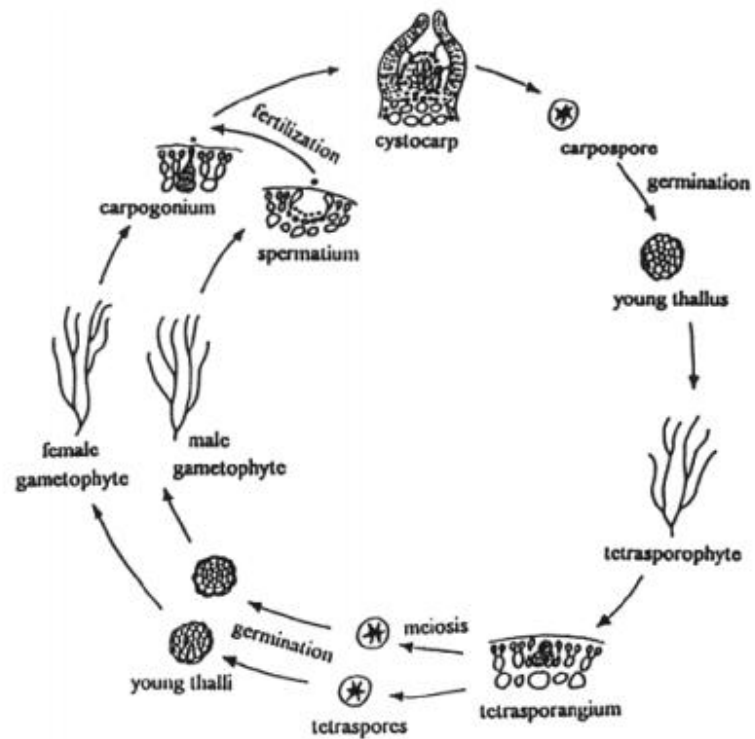

Figure 5. The life cycle of *Gracilaria* (FAO/NACA, 1996)

Biochemical of *Gracilaria*

The main productions are as food and as sources of hydrocolloids: agar and carrageenan. Agar production, the first phycocolloid is discovered and prepared as a purified extract. Agar is essentially a mixture of the neutral polymer agarose, pyruvated agarose and sulfated galactans. The structure of agar consists of alternating β -1,3 and α -1,4 linked D and L galactose residues, respectively. The gel-forming properties of agar are widely used in pharmaceutical, cosmetics and food industry. Gel strength (upon gelation) of this species is very low compared with *Gelidiales*. Agar content has depended on the collection site, season, physiological, development stage, conditions of cultivation and extraction mode. (Marinho-Soriano, 2001; Marinho-Soriano and Bourret, 2003; Hong *et al.*, 2007).

Environmental Factors

Growth, pigments, photosynthetic activity and agar quality of *Gracilaria* sp. were influenced by salinity, light intensity, temperature, turbidity and nutrients (Table 1).

Table 1. Summary of some studies on the effects of salinity, light intensity, temperature, turbidity and nutrients on *Gracilaria* sp.

Environmental factors	Species	Results	Reference
Salinity	<i>G. tikvahiae</i>	<i>G. tikvahiae</i> was a euryhaline species (16-26‰), decreased photosynthesis and increased dark respiration when salinity decreased causing hypo-osmotic shock.	Lapointe <i>et al.</i> , 1984
Salinity	<i>G. verrucosa</i>	<i>G. verrucosa</i> collected at 32‰ salinity and cultured in the same salinity for 20 days showed lower photosynthetic responses when cultured in 10‰ salinity. This study suggested a distinct mechanism of osmoregulation after a hypo or hyperosmotic shock, where respiratory rates did not change significantly.	Koch and Lawrence, 1987.
Salinity	<i>G. sordida</i> and <i>G. tenuistipitata</i>	An α -galactosidase decreased upon transfer of the algae to hypersaline medium and increased upon transfer to hyposaline. In growth experiments, α -galactosidase activity was found to be dependent on the salinity of the growth medium, with high activity in	Yu and Pedersen, 1990.

Table 1. *Continued.*

Environmental factors	Species	Results	Reference
Salinity	<i>G. tenuistipitata</i> var <i>Liui</i>	hyposaline medium and low activity in hypersaline medium. <i>Gracilaria</i> grew better under low salinity (21‰) condition, the daily growth rate was 37.6% higher. Agar yield was found to be negatively correlated to the tissue nitrogen contents, and positively correlated to the C: N ratios.	Li-hong <i>et al.</i> , 2002.
Salinity	<i>G. birdiae</i>	The alga was cultivated under field conditions in an estuary over a 6-months period, mean of salinity was 36.1±1.85‰. Correlation analysis showed that RGR was negatively correlated with salinity (R-Pearson= 0.41; p<0.05). This correlation was used in a mathematical regression model to estimate the growth of <i>Gracilaria</i> in an estuary.	Marinho-Soriano <i>et al.</i> , 2006

Table 1. *Continued.*

Environmental factors	Species	Results	Reference
Light	<i>Gracilaria</i> sp.	<p>The optimal photon fluence rate for growth was low (about $100 \mu\text{E}\cdot\text{s}^{-2}\cdot\text{s}^{-1}$); higher photon fluence rates inhibited growth. Both phycoerythrin (PE) and chlorophyll (Chl) contents decreased with increasing photon fluence rates (up to $100 \mu\text{E}\cdot\text{s}^{-2}\cdot\text{s}^{-1}$) inverted to the growth response. Plants grown at 60 and $140 \mu\text{E}\cdot\text{s}^{-2}\cdot\text{s}^{-1}$ showed higher light compensation and saturation points. The pigment relations of the algae did not change in a direction complementary to the light composition. This, together with the relatively higher photosynthetic rates under reddish and blueish light cause by chromatic adaptation of the pigments.</p>	Beer and Levy, 1983
Light	<i>G. tenuistipitata</i>	<p>In plants, excess irradiation can damage the photosynthetic apparatus, although some protective mechanisms exist. Decreasing the irradiance resulted in a clear saturating response of the synthesis</p>	Carnicas <i>et al.</i> , 1999

Table 1. *Continued.*

Environmental factors	Species	Results	Reference
Temperature	<i>G. tenuistipitata</i> var. <i>liui</i>	<p>of Chl <i>a</i> and β-carotene after one to two days. Biliprotein synthesis displayed a double linear trend, the first one lasting for four days in the cases of both R-phycoerythrin (RPE) and R-phycoyanin (RPC). The response of zeaxanthin is always faster than that of Chl <i>a</i> or biliproteins to changes of irradiance.</p> <p>Season significantly affected: 1) the specific growth rate was different between winter (January, 1996-1998) and summer (August, 1996-1998), which grew in a range of 14.1-32.3°C and 11.8-37.3°C with the maximum at 23 and 24.5°C, respectively., 2) the recovery specific growth rate after transferal to 25°C showed a similar trend and 3) free proline accumulated only in summer plants at both 20 and 35°C.</p>	Lee <i>et al.</i> , 1999

Table 1. *Continued.*

Environmental factors	Species	Results	Reference
Turbidity	<i>Gracilaria</i> spp.	Sediment reduces underwater irradiance and burials/smothering the plants, limiting production. The algae at the estuaries carrying considerable silt were more fragile than those growing in clearer water.	Perez and Barbaroux, 1996
Salinity and temperature	<i>G. tenuistipitata</i> var. <i>liui</i>	The growth rates were lowest at 15°C (lowest temperature) and 32°C (highest temperature). Growth rate was over 2% from 20-30°C and peaked at 21‰, with a broad plateau between 7-27‰. Maximum photosynthetic rate was obtained at 21‰. Lower or higher salinity was unfavorable for growth. At 3‰ salinity decolonization of apical segments occurred within two days and necrosis occurred after four days while at 34‰, segments grew slender and branches were softer, while at 47‰, segments discolored after 2 weeks.	FAO, 1990

Table 1. *Continued.*

Environmental factors	Species	Results	Reference
Light and nutrient	<i>G. firma</i>	Growth experiments under various light and ammonium combinations showed that the highest photon flux density level (900 $\mu\text{mol m}^{-2}\text{s}^{-1}$) and moderate ammonium (150 $\mu\text{M NH}_4\text{Cl}$) concentration gave the highest growth rates.	Araño <i>et al.</i> , 2000
Salinity and temperature	<i>G. verrucosa</i> and <i>G. chorda</i>	Both species grew over a wide range of temperatures (10-30 °C) and salinities (5-35‰), and grew well at 17-30 °C and a salinity of 15-30‰, their maximum growth rates were 4.95% day^{-1} (30 °C, 25‰) and 4.47% day^{-1} (at 25 °C, 25‰), respectively.	Choi <i>et al.</i> , 2006
Salinity and Light	<i>G. asiatica</i>	Higher survival rate of <i>G. asiatica</i> was observed with the 20- and 60-krad doses. The protein content and composition of selected seaweeds were analyzed and compared with the control. SDS-PAGE showed no remarkable difference in the protein composition between	Hong <i>et al.</i> , 2007.

Table 1. *Continued.*

Environmental factors	Species	Results	Reference
Salinity, Temperature and light	<i>G. tikvahiae</i>	<p>the control and irradiated samples. However, the 67-kDa protein band of seaweed treated with 20 and 60 krad, then grown on ESS-1 medium with 23% NaCl, had a higher density than other samples.</p> <p>The net photosynthesis was light-saturated at 200-600 $\mu\text{E}\cdot\text{m}^{-2}\cdot\text{s}^{-1}$ depending upon the season and incubation temperature. No light inhibition was observed up to the maximum 5 and 25 °C. Maximum net photosynthesis occurred between 25 and 35 °C, while rates decreased at 37.5 °C. The net photosynthesis responses at 25 and 30 °C were stable after acclimation times of one to four days, but declined after three days at 35 °C. <i>G. tikvahiae</i> had an euryhaline net photosynthetic response between 5‰ and 40‰.</p>	Penniman and Mathieson, 1985.

Table 1. *Continued.*

Environmental factors	Species	Results	Reference
Salinity, Temperature and light	<i>G. verrucosa</i>	The alga had been grown in sustained cultivation over a period of five years. Productivities ranged from 3-31 g dry wt m ⁻² d ⁻¹ and were generally highest in summer when annual water temperatures and daily irradiances were highest. In summer, agar yield was appeared lowest whereas the gel strength was highest (> 750 g cm ⁻²).	Bird and Ryther, 1990
Salinity, light and nutrient	<i>Gracilaria sordida</i>	Floridoside increased significantly under conditions of darkness and high salinity. A decrease in salinity, indicating increased floridoside degradation under these conditions. Starch degradation occurred during darkness, predominantly in enriched tissue on exposure of algae to hypersaline followed by hyposaline conditions. Nutrient-starved algae showed increased agar yield when subjected to altered salinity. Unchanged salinity and darkness resulted in decreased agar yield.	Ekman <i>et al.</i> , 1991

Table 1. *Continued.*

Environmental factors	Species	Results	Reference
Salinity, temperature and light	<i>G. cornea</i>	The alga showed compensation and saturation irradiances at low irradiances (11-38 and 90-127 $\mu\text{mol photon m}^{-2} \text{ s}^{-1}$), indicating acclimation to lower irradiances in their shallow (1-2 m depth) habitats where turbidity was high. In comparison with other species of <i>Gracilaria</i> , <i>G. cornea</i> had lower levels of pigment, but similarly high photosynthetic efficiency, demonstrating shade adaptation; it had only limited tolerance to salinities below 20‰ and temperatures below 15 °C.	Dawes <i>et al.</i> , 1999.
Salinity, temperature and Seawater pH	<i>Gracilaria</i> spp.	This study showed broad salinity tolerance and its ability to sustain growth rates in outdoor cultures. Growth under laboratory conditions was influenced by all three variables studied, namely, temperature (20 or 30 °C), salinity (20, 30 or 39‰) and seawater pH (6.5, 7.0, 8.0 or ≥ 9.0). In outdoor tanks, weekly growth and agar yields were	Israel <i>et al.</i> , 1999

Table 1. *Continued.*

Environmental factors	Species	Results	Reference
Salinity, temperature and light	<i>Gracilaria Greville</i>	<p>enhanced by increasing light intensities (up to full sunlight) and nutrient concentrations (up to 0.2 $\mu\text{M PO}_3^{2-}$ and 2.0 $\mu\text{M NH}_4^+$), and rates averaged four times higher than rates determined in the smaller flask cultures.</p> <p>The algae were collected from Japan, India and Malaysia. Growth rate experiments were conducted at different temperatures, salinities and light intensities. The growth rates of all species varied with salinities, but most of them attained their optimum growth rates at normal seawater salinity at 35‰.</p>	Raikar <i>et al.</i> , 2001
Salinity, temperature and light	<i>G. chorda</i>	The optimum photon irradiance for growth was 60-120 $\mu\text{mol photons m}^{-2}\text{s}^{-1}$. Instead of using ordinary sea salt (NaCl) to prepare artificial seawater, ultra pure salt was adopted. The alga grew faster in	Kakita and Kamishima, 2006

Table 1. *Continued.*

Environmental factors	Species	Results	Reference
Salinity, temperature and light	<i>G. salicornia</i>	<p>artificial seawater made with ultra pure salt, probably because the former medium was clear, while the latter was milky.</p> <p>This alga showed adaptability in its photosynthetic and respiratory responses to oceanic salinity as well as to subtropical to tropical temperature. Significant differences in the photosynthetic and respiratory rates among the <i>G. salicornia</i> populations collected from the various sites were observed. The Phuket population showed adaptability to high irradiance and temperature, characteristic of its natural sun-exposed environment, as it exhibited the highest I_k and I_c, and lowest α and higher P max at 30-35 °C. On the other hand, the Okinawa population demonstrated adaptability to low submarine irradiance as it had a lower I_k and I_c than either population from Thailand. Its P max at 20-25 °C was also higher than that of the</p>	Phooprong <i>et al.</i> , 2007.

Table 1. *Continued.*

Environmental factors	Species	Results	Reference
Salinity, temperature and light	<i>G. lichenoides</i> and <i>G. tenuistipitata</i>	<p>Phuket population. The Rayong population, however, showed the highest P max, Rd, α, Ik and Ic, suggesting its adaptability to both sun and shade light conditions in its natural environment.</p> <p>The best growth rate was obtained under the conditions of 32 °C, 30 PSU and 240 μmol/(m²·s) and 24 °C, 20 PSU and 200 μmol/(m²·s) for <i>G. tenuistipitata</i>. The highest daily specific growth rates were determined to be at 31.30 °C, 32.10 PSU, and 287.23 μmol/(m²·s) for <i>G. lichenoides</i> (16.26%/d), and 25.38°C, 21.10 PSU, and 229.07 μmol/(m²·s) for <i>G. tenuistipitata</i> (14.83%/d).</p>	Yongjian <i>et al.</i> , 2009.
Salinity, temperature, light and	<i>Gracilaria</i> sp.	The physical variables include tank and pond structure, seawater characteristics such as velocity, agitation practice, exchange rate, and salinity, light (quantity and quality), and temperature were affecting	Friedlander and Levy, 1995

Table 1. *Continued.*

Environmental factors	Species	Results	Reference
nutrient		the <i>Gracilaria</i> annual yield and the updated solutions evolved. The chemical variables included nutrient composition and regime of application, and inorganic carbon supply with the pH changes involved.	

Research question

“There are any differences in salinity, light intensity and sediment in Songkhla lagoon. If so, could these influence distribution and abundance of *G. tenuistipitata*? ; how these affect growth, pigment contents, agar production and reproduction on *G. tenuistipitata*?”

Hypotheses

Null hypotheses

H_{0A}: Salinity does not affect on growth, pigments, agar production and reproduction in *G. tenuistipitata*.

H_{0B}: Light intensity does not affect on growth, pigments, agar production and reproduction in *G. tenuistipitata*.

H_{0C}: Sediment does not affect growth, pigments, agar production and reproduction in *G. tenuistipitata*.

H_{0D}: There is no relationship between the combination (salinity, light intensity and sediment) and *G. tenuistipitata*.

Alternative hypotheses

H_{1A}: Salinity does affect on growth, pigments, agar production and reproduction in *G. tenuistipitata*.

H_{1B}: light intensity does affect on growth, pigments, agar production and reproduction in *G. tenuistipitata*.

H_{1C}: Sediment does affect on growth, pigments, agar production and reproduction in *G. tenuistipitata*.

H_{1D}: There is relationship between the combination (salinity, light intensity and sediment) and *G. tenuistipitata*.

Objectives

1. To investigate salinity, light intensity and turbidity in Songkhla lagoon, to use as baseline information for experimental testing in laboratory.
2. To study the effects of salinity, light intensity and sediment on growth, pigments, agar production and reproduction of *G. tenuistipitata*.

CHAPTER 2

MATERIALS AND METHODS

Study site

The study was carried out at four sites (LP; Laemphor Temple, KP; Khokpeaw Temple, TY; Taiyor Temple, KB; Khaobor Temple), which were located around Koh Yor (94° 29' 12", 5° 58' 30"), Songkhla lagoon, Songkhla Province, Southern Thailand (Figure 6). The site is known to have an abundance of *Gracilaria* sp.; Koh Yor covers area of 15 square kilometers on the lower part of Songkhla lagoon. There are two dominant seasons: (Office of natural resources and environmental policy and planning, 2004):

1) Dry season is dominated by East monsoon (February to April), April is the hottest month.

2) Rainy season could be separated into 2 parts:

- The first is dominated by Southwest monsoon (May to September)
- The second is dominated by Northeast monsoon (October to January) having a heavy rain with highest rain in November.

Salinity in the lagoon is depended on the proportions of river water and seawater from tidal change, thus salinity increases during high tide. However, the recent development and construction have changed the balance of freshwater and seawater causing the changing of salinity within the lagoon. There are 3 species of *Gracilaria* in this area: *G. tenuistipitata* C.F. Chang & B.M. Xia, *G. percurrrens* (Abbott) Abbott and *Hydropuntia fisheri* (B.M. Xia & I.A. Abbott) M.J. Wynne (Lewmanomont and Ogawa, 1995). They occur on the soft-bottom and hard substrates in the shallow bay from 0-5 m.

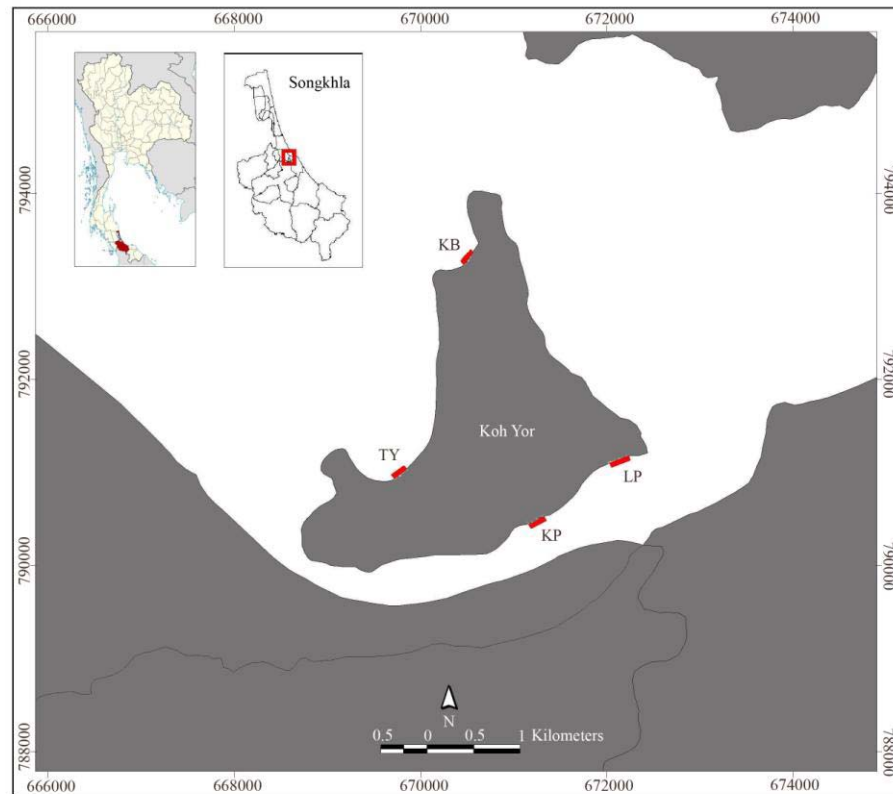

Figure 6. Sampling sites at Koh Yor, Songkhla lagoon, Songkhla Province, Thailand (LP; Laemphor Temple, KP; Khokpeaw Temple, TY; Taiyor Temple, KB; Khaobor Temple).

The soft bottom was clay with hydrogen sulfide in bottom of the lagoon. Khokpeaw Temple and Taiyor Temple were shallower (approximately 1.0-1.5 m) than Laemphor Temple and Khaobor Temple (approximately 1.5-1.9 m). Recently, there were various constructions such as artificial reef at Khokpeaw Temple and a waterfront pavilion at Taiyor Temple, causing the changing of bottom and increasing accumulation of sediment. (Figure 7)



Laemphor Temple (LP)



Khokpeaw Temple (KP)



Taiyor Temple (TY)



Khaobor Temple (KB)

Figure 7. Many substrates are found at coastlines such as artificial reef at Khokpeaw Temple (KP).

Methods

1. Field study

The Environmental parameters and algal abundance were monthly investigated at 4 sites around the coast at Koh Yor during 2006 to 2007. Salinity was measured using salinity refractometer (ATC, 0-100 ppt, XHO RHS-10ATC, ATACO, China). Light intensity was measured using a light meter (Li-Cor, LI-250A, LI-COR Inc., USA). Transparency and temperature were measured using secchi disk and thermometer respectively.

The ambient underwater light intensity in each month was calculated by the regression between bottom light intensity and amount of sediment suspension during January to December (2006 to 2007), using following equation:

$$Y = -10995X + 780 \quad ; R^2 = 0.9304, P < 0.01$$

Y = underwater light intensity ($\mu\text{mol photons m}^{-2}\text{s}^{-1}$)

X = amount of sediment suspension (mg/l)

This equation calculated by finding the relationship between amount of sediment suspension and underwater light intensity from May to July 2007; a total of 36 samples were examined (Appendix 1).

The nutrients data (Nitrogen and phosphorous) were provided by The National institute of coastal aquaculture, Songkhla province and the study of Buakaew (2005) (personal communication) from January to December (2006 to 2007), however some months are missing. Sediment and water samples were collected by suspended sediment traps made from PET water bottle, diameter 13.5 cm (5 traps per site) at 50 cm above the bottom (Figure 8). After 24 hrs, the traps were brought back to laboratory.

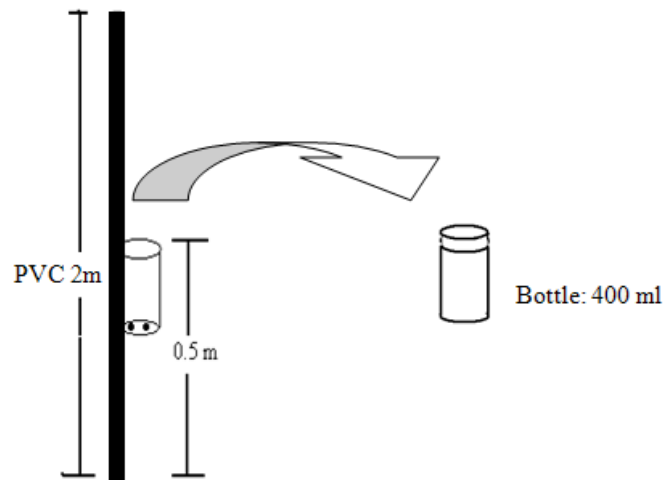

Figure 8. The sediment trap was used to trap suspended sediment for 24 hrs.

Sediment was washed and dried at 30 °C for 6 days, 10% H₂O₂ (v/v) was added and left for 24 hrs to remove organic matter. Then 10% H₂O₂ (v/v) was removed by boiling and rinsed the sediments with distilled water. Grain sizes were investigated using particle size analyzer (LS 13 320, Beckman Coulter) and dried again at 60 °C for 24 hrs (Buakaew, 2005). The sediment was kept for further uses in laboratory. Each sediment size was weighed.

G. tenuistipitata was collected from Songkhla lagoon, Koh Yor during March to November 2006. Then they were brought back to the laboratory in a foam container with air pump and washed with seawater in order to remove sand and mud, epiphytes were also cleaned and kept in the filtered seawater tanks for 7 days under daylight, ambient temperature at 28 ppt, air supply was given using air pump for acclimate the algae.

2. Laboratory study

2.1 Laboratory set up

The experiments were set up to test the effects of light, salinity and sediment of *G. tenuistipitata* in short-term (3 days) and long-term (20 days) conditions (Figure 9).

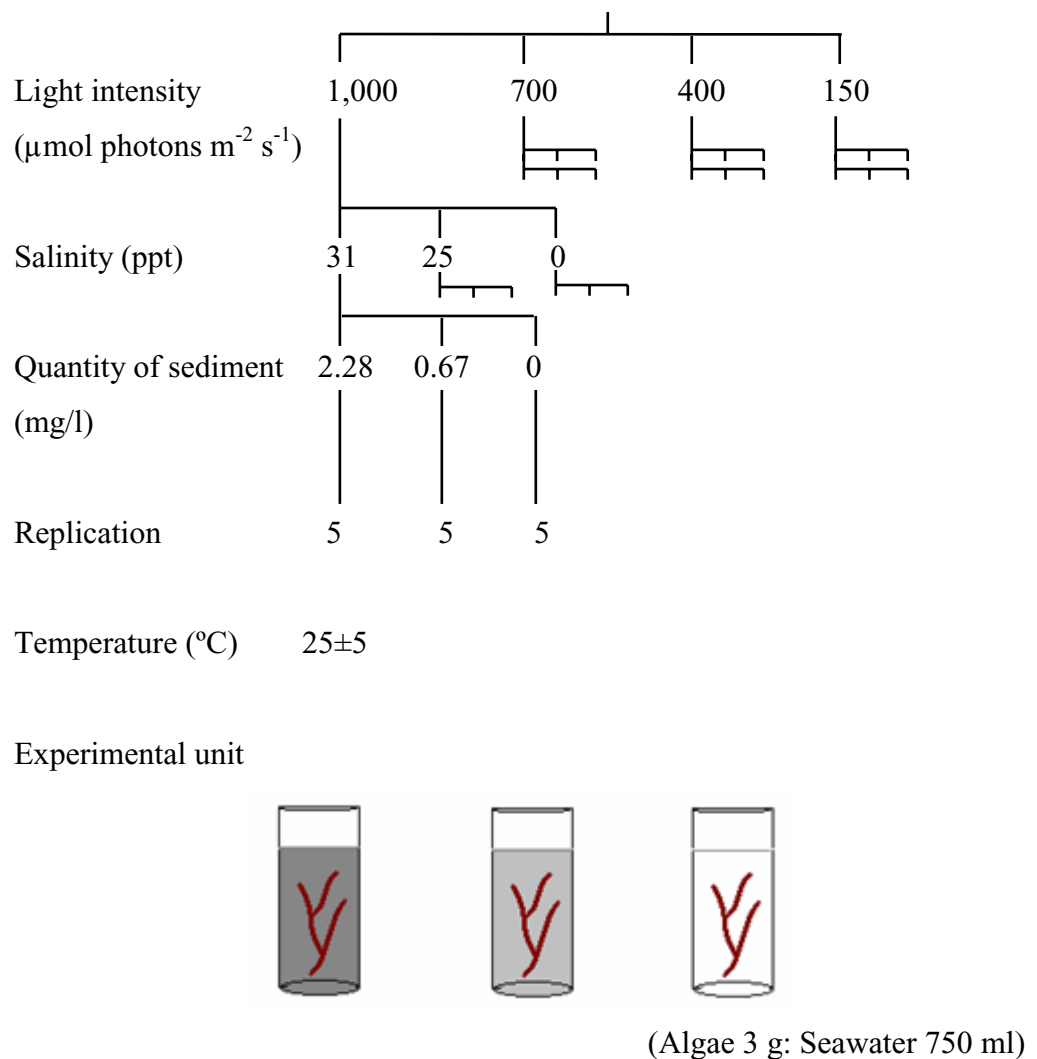

Figure 9. Flow chart showing experimental design in the laboratory.

Three grams wet weight of *G. tenuistipitata* was incubated in 700 ml. sterilized seawater, at 25 \pm 5 $^{\circ}\text{C}$, for 5 days before the experiments; this would allow the algae to acclimate. Algal specimens were photographed before and after the experiments using a digital camera (Canon, PowerShot SX100 IS). This was to compare the morphological characters of the algae.

The culture medium consisted of filtered natural seawater (What-man GF/F) with 3 salinities: 31, 25 and 0 ppt. The average concentrations of nitrate and phosphate all the year round, were 0.096 \pm 0.017 and 0.281 mg/L, respectively (NICA, personal communication, Appendix 2). This was found in the field during the

preliminary study. The medium were renewed every three days and enriched nitrogen and phosphorus by using NaNO_3 0.799 mg/l and Na_3PO_4 1.486 mg/l, respectively. Aeration was provided by bubbling with air pump at rate 3.4 min^{-1} (Daivo pump, NS 8200) to stir the sediment.

Horizontal day light was continuously provided using fluorescent lamps (Philips, TL-D SUPER 80 58W/865 SLV/25) at 1000, 700, 400 and $150 \mu\text{mol photons m}^{-2}\text{s}^{-1}$, (Day light 12 h: Dark 12 h), which was found in the field during the preliminary study (Figure 10). Electric fans were used to help keeping the temperature in the high light intensity set up.



Figure 10. The experiments were set up in laboratory, by manipulating salinity, light intensity and sediment.

The amount of sediment in each experiment was varied, 2.28 mg/l represented the rainy season, 0.67 mg/l represented the dry season and 0 mg/l was control, respectively. Algae were cultivated for 3 days (short term) and 20 days (long term), the experiments had to be aborted at 20 days because of epiphytes (in preliminary study). The photosynthesis performance of algae was measured on short and long terms cultured. Wet weight would be estimated, pigments and agar concentration were investigated at the end of cultivation.

2.2 Laboratory analyses

2.2.1 Morphology and reproduction

The change of color, new thalli and reproductive cell of *G. tenuistipitata* were observed and recorded under each condition.

2.2.2 Biomass

In long term experiment, since there was an instant change in biomass, algae were harvested, weighed (wet weight) and recorded. Biomass was calculated by following:

$$\%WG = \frac{A - B}{B} \times 100$$

%WG = percentage of weight gain

A = weight after culture

B = weight before culture

2.2.3 Pigment analysis

Chlorophyll *a* was extracted by grinding 0.3 and 0.5g wet weight of *G. tenuistipitata* thalli in 90% acetone. After centrifugation (Model H-103N Series, Kokusan) at 2,000 rpm for 20 min, the supernatant solution was analyzed for chlorophyll *a* using absorption spectrophotometry (Model Genesys 10VIS, Thermo Electron Corporation). Pigments were calculated by following:

$$\text{Chl } a \text{ (mg.l}^{-1}\text{)} = 11.41 A_{664} - 0.40 A_{630}$$

(Jeffrey and Humphrey, 1975)

Phycobilins was extracted by grinding 0.5g wet weight of *G. tenuistipitata* thalli in 0.05 M phosphate buffer (pH = 6.8) and centrifugation at 2000 rpm for 20 min. The phycoerythrin (PE) and phycocyanin (PC) were determined using spectrophotometrically and calculated by following:

$$\text{PC } (\mu\text{g/ml}) = 151.1 A_{614} - 99.1 A_{651}$$

$$\text{PE } (\mu\text{g/ml}) = 155.8 A_{498.5} - 40.0 A_{614} - 10.5 A_{651}$$

(Kursar *et al.*, 1983)

2.2.4 Photosynthesis and respiration

The effect of light intensity on photosynthesis rate in *G. tenuistipitata* was measured in the laboratory using 0.1 g of thallus. These samples were placed in closed chambers connected to dissolve oxygen meter (MI 605, Martini instruments) and expressed in mg/L (ppm) O₂. The oxygen evolution was first monitored at darkness for 15 min, and increasing irradiance exposure afterwards: 100 to 2,200 $\mu\text{mol photons m}^{-2}\text{s}^{-1}$, for 5 min each at 25 °C. Halogen (Halotone, 220-240V, 50W, SP Electric) was used as a light source.

2.2.5 Agar extraction

The agar extraction was done using the method described by Marinho-Soriano (1999). Each dried sample (dried for 24 h at 60 °C) was added to 30 ml of distilled water, adjusted to pH 6.5 in an Erlenmeyer flask and heated for 1 h at 110 °C in an autoclave (Hiclave HVE-50, Hirayama). The extracts were filtered through a glass fiber filter (Whatman GF/C). The extracts were allowed to gel at room temperature and then placed in a freezer (15 °C) overnight. The frozen gel was thawed, washed with distilled water and dried for 24 h at 60 °C. The agar yield (%) was calculated as the percentage of dry matter.

3. Statistical Analyses

SPSS Version 13.0 for Windows was used to analyze the data at significance levels of 95%. The data (and data transformed with Log(X), Log(X+1) or square root(X)) of biomass, pigment content, agar yields, photosynthesis and respiration were tested for normal distribution by Levene's Test.

The field study data were analyzed using One-way ANOVA to test for differences of between subjects (year and month). A three-way ANOVA was used to analyze the effects of the physiological parameters; salinity, light intensity and sediment on biomass, pigment content, agar yields, photosynthesis and respiration of *G. tenuistipitata*.

Stepwise multiple regression was employed to test the effects of the physiological treatment on biomass, pigment content, agar yields, photosynthesis and respiration of *G. tenuistipitata*.

CHAPTER 3

RESULTS

Songkhla lagoon is influenced by seasonal and the environmental factors i.e. salinity, light, sediment load, tides and by human such as fishery and development around Songkhla lagoon, which negatively affected *Gracilaria* spp. population. *Gracilaria* spp. were found attached on various habitats i.e. rock, shells, broken stones, pebbles, polyethylene bags, garbage, fish cages and buildings, at 10 to 60 cm below water surface; and the population was rather small and in decline.

1. Environmental parameters

There were significant differences in air temperature, water temperature, salinity, transparency, light intensity and sedimentation among months during January 2006 to December 2007 ($P < 0.05$) (Table 2).

Table 2. Summary of physical and chemical parameters of the environmental parameters during January 2006 to December 2007 at Koh Yor

Source of variation					
Between subjects	<i>df</i>	Min-Max	Mean \pm SE	Chi-Square	P
Month					
Air temperature ($^{\circ}\text{C}$)	11	25.00-36.00	29.92 \pm 2.61	61.139	0.000
Water temperature ($^{\circ}\text{C}$)	11	25.00-36.00	30.75 \pm 2.14	43.736	0.000
Salinity (ppt)	11	0.00-33.00	14.45 \pm 11.60	53.260	0.000
Transparency (cm)	11	8.50-95.50	40.24 \pm 18.41	35.493	0.000
Underwater Light intensity					
($\mu\text{mol photon m}^{-2}\text{s}^{-1}$)	11	394.63-720.14	656.01 \pm 16.95	65.367	0.000
Sedimentation(mg/l/year)	11	0.05-7.20	1.33 \pm 1.07	59.856	0.000

1.1 Temperatures

There was similar pattern in temperature from January 2006 to December 2007. The average air temperature and water temperature during noon were 29.92 ± 2.61 °C and 30.75 ± 2.14 °C respectively (Figure 11 and 12). The lowest temperature, 25 °C, occurred from June to January (rainy season) and the highest temperature, 36 °C, was found in February to May (dry season).

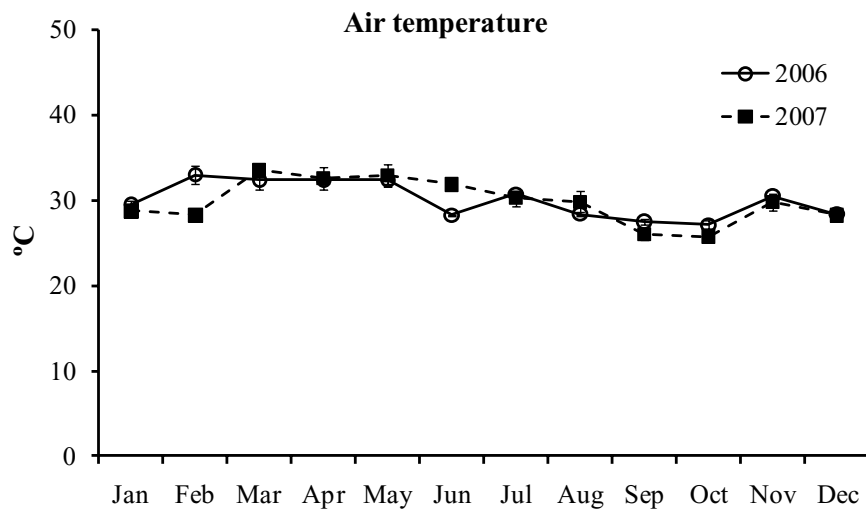

Figure 11. Seasonal changes in air temperature from January 2006 to December 2007. The error bars are standard error. (n=144)

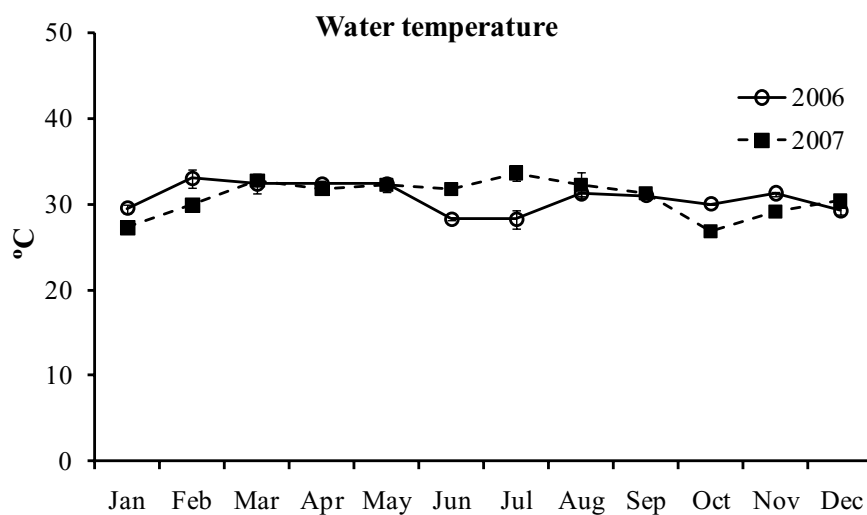

Figure 12. Seasonal changes in water temperature from January 2006 to December 2007. The error bars are standard error. (n=144)

1.2 Salinity

There was similar pattern in salinity from January 2006 to December 2007. The average salinity was 14.45 ± 11.60 ppt. There was 2 ranges of salinity; low salinity and high salinity, depended on the proportions of rainfall and fresh water run-off from terrestrial system. The highest salinity was 33 ppt during January to April (dry season) and August to September (rainy season) and the lowest salinity was 0 ppt. during May to July and October to December (rainy season) except in December 2005 to January 2006 (before dry season) due to unexpected heavy rainfall (Meteorological Department, 2004) which decreased salinity in dry season. (Figure 13)

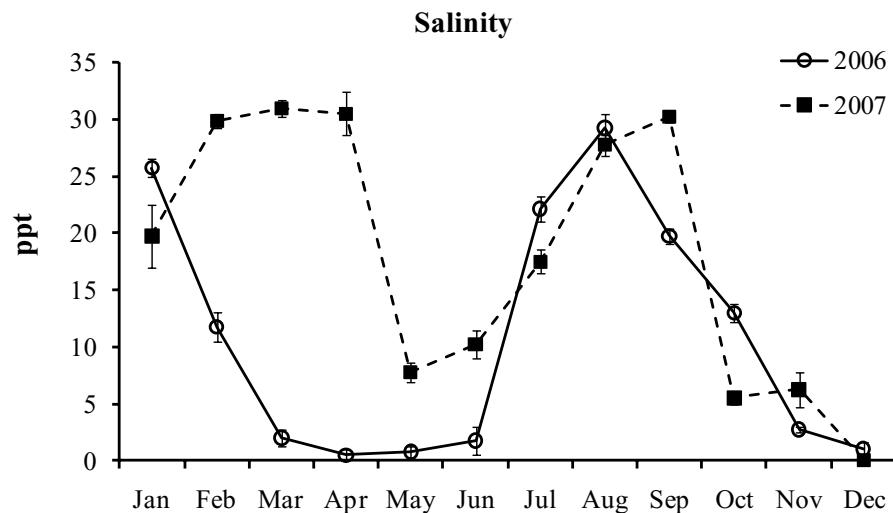

Figure 13. Seasonal changes in salinity from January 2006 to December 2007. The error bars are standard error. (n=144)

1.3 Transparency

The average transparency in January 2006 to December 2007 was 40.24 ± 18.41 cm (Figure 14). There was difference in transparency between seasons; low transparency and high transparency, depended on suspended of particles. The high transparency was 62.87 ± 3.29 cm during February to April (dry season) and the low transparency was 32.19 ± 3.17 cm during August to December (rainy season) because of high wave motion and increasing sediment load by run-off from river and land in rainy season. However, during 2006, the site was affected by big flood, the

lowest transparency (8.50 cm) occurred in May 2006, and the highest transparency (95.50 cm) occurred in October 2006.

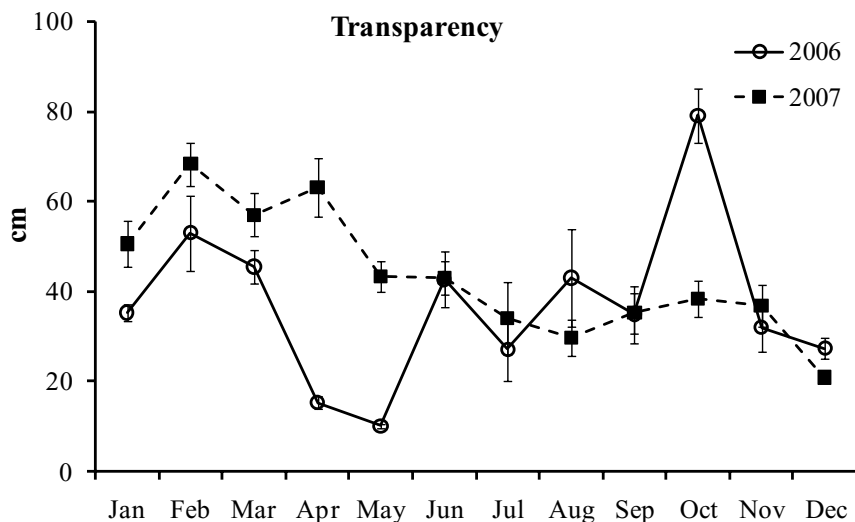

Figure 14. Seasonal changes in transparency from January 2006 to December 2007. The error bars are standard error. (n=144)

1.4 Light intensity

The average underwater light intensity during noon in January 2006 to December 2007 was $656.01 \pm 16.95 \mu\text{mol photon m}^{-2}\text{s}^{-1}$. The lowest underwater light intensity was $394.63 \pm 147.96 \mu\text{mol photon m}^{-2}\text{s}^{-1}$ in July 2007 (rainy season) and the highest underwater light intensity was $720.14 \pm 6.33 \mu\text{mol photon m}^{-2}\text{s}^{-1}$ in October 2006 (rainy season) (Figure 15).

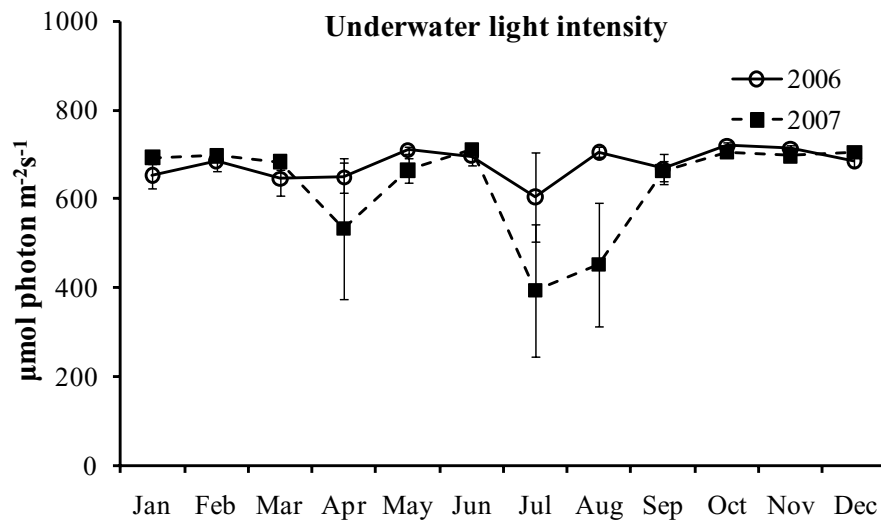

Figure 15. Seasonal changes in light intensity from January 2006 to December 2007. The error bars are standard error. (n=144)

1.5 Sedimentation

The average sedimentation in January 2006 to December 2007 was $3.29 \pm 0.1 \text{ mg/l/d}^{-1}$. The lowest sedimentation was 0.05 mg/l/d^{-1} in October 2006 (rainy season) and the highest sedimentation was 7.20 mg/l/d^{-1} in August 2007 (dry season) (Figure 16). The sedimentation was influenced by high wave motion, fresh water run-off; high sedimentation occurred in dry season during February to April while low sedimentation occurred in rainy season during October to January.

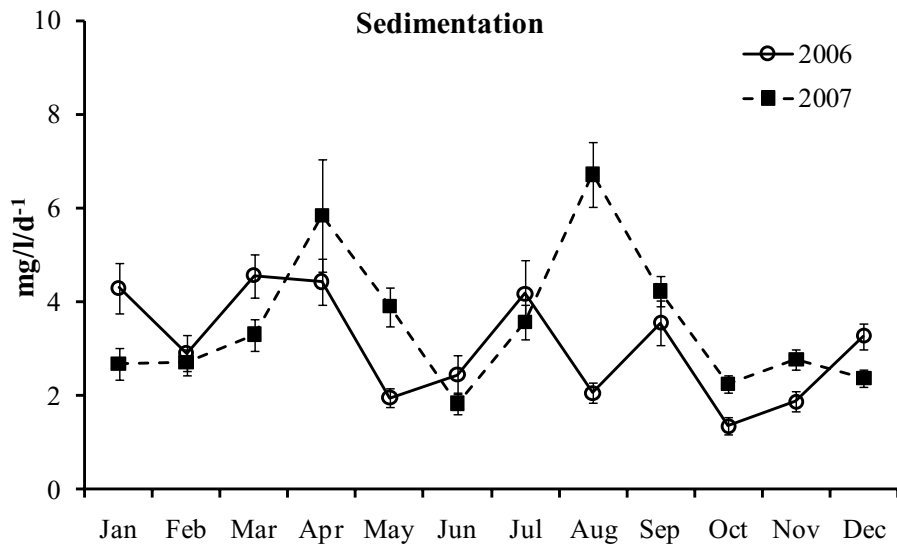

Figure 16. Seasonal changes in sedimentation from January 2006 to December 2007. The error bars are standard error. (n=144)

There were significant differences in amount of sediment and grain size among months. The amount and type of sediment from the sediment traps at Koh Yor were 3.070.09 mg/l/year. The category was as fine silt (11-16 μm) as shown in Figure 17.

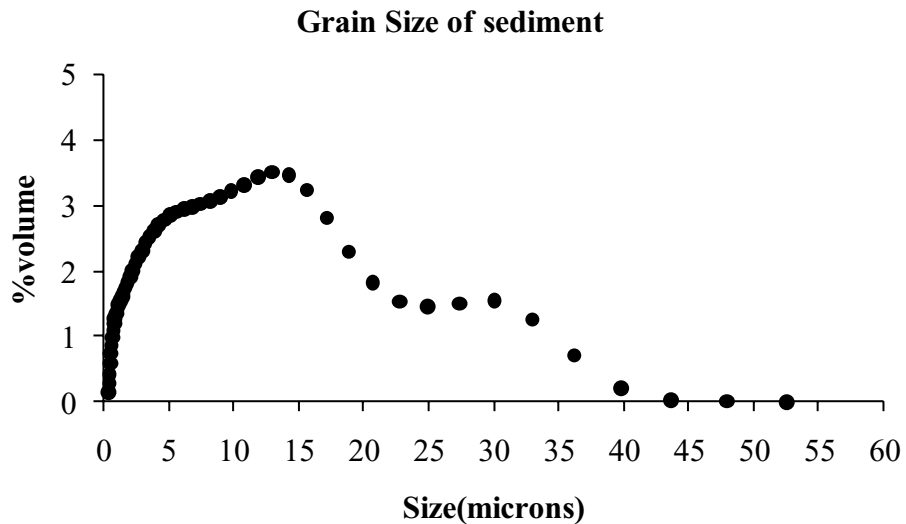

Figure 17. Grain size of sediment at Koh Yor during April 2006 to January 2007. (n=120)

2. Population of *G. tenuistipitata*

G. tenuistipitata population was surveyed in Songkhla lagoon. The algae were observed in early rainy season (May to October) and in late rainy season (January to March). The disappearance of *G. tenuistipitata* during December to January might be because of a very low salinity (Figure 18).

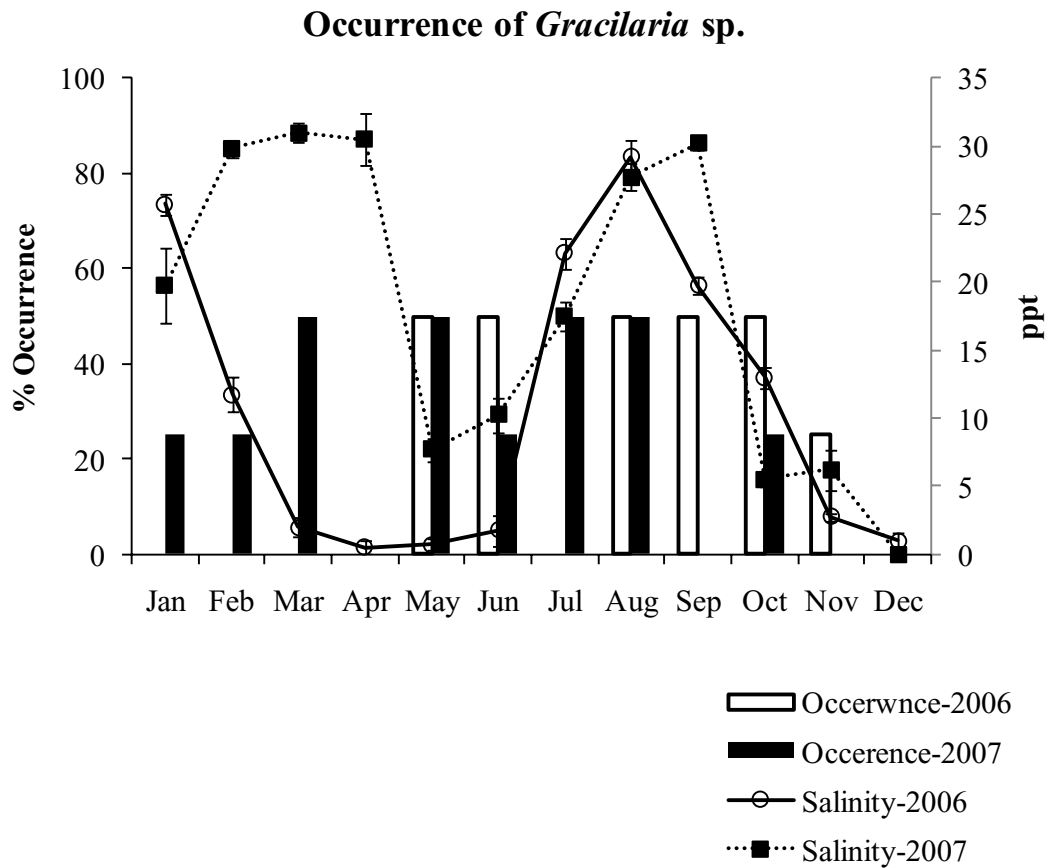

Figure 18. Occurrence of *Gracilaria* spp. population compares with salinity at Koh Yor between January 2006 to December 2007.

3. Morphology

Color and shape of thallus were changed after the experiment (Figure 19 to 22). The algae growing at low light intensity ($150\text{--}400\ \mu\text{mol photons m}^{-2}\text{s}^{-1}$), 25 ppt and no sediment became green, while at high light intensity ($1,000\ \mu\text{mol photons m}^{-2}\text{s}^{-1}$) the algae bleached.

Thalli covered by sediment had darker color; frond became fragile and easily breaks in 0 ppt combinations with high light intensity. There were no reproductive fronds observed.

Light intensity: $150\ \mu\text{mol photons m}^{-2}\text{s}^{-1}$



Figure 19. *G. tenuistipitata* after cultured under $150\ \mu\text{mol photons m}^{-2}\text{s}^{-1}$ of light intensity condition in each salinity and 3 levels of sediment for 20 days.

Light intensity: $400 \mu\text{mol photons m}^{-2}\text{s}^{-1}$



Figure 20. *G. tenuistipitata* after cultured under $400 \mu\text{mol photons m}^{-2}\text{s}^{-1}$ of light intensity condition in each salinity and 3 levels of sediment for 20 days.

Light intensity: $700 \mu\text{mol photons m}^{-2}\text{s}^{-1}$



Figure 21. *G. tenuistipitata* after cultured under $700 \mu\text{mol photons m}^{-2}\text{s}^{-1}$ of light intensity condition in each salinity and 3 levels of sediment for 20 days.

Light intensity: $1,000 \mu\text{mol photons m}^{-2}\text{s}^{-1}$

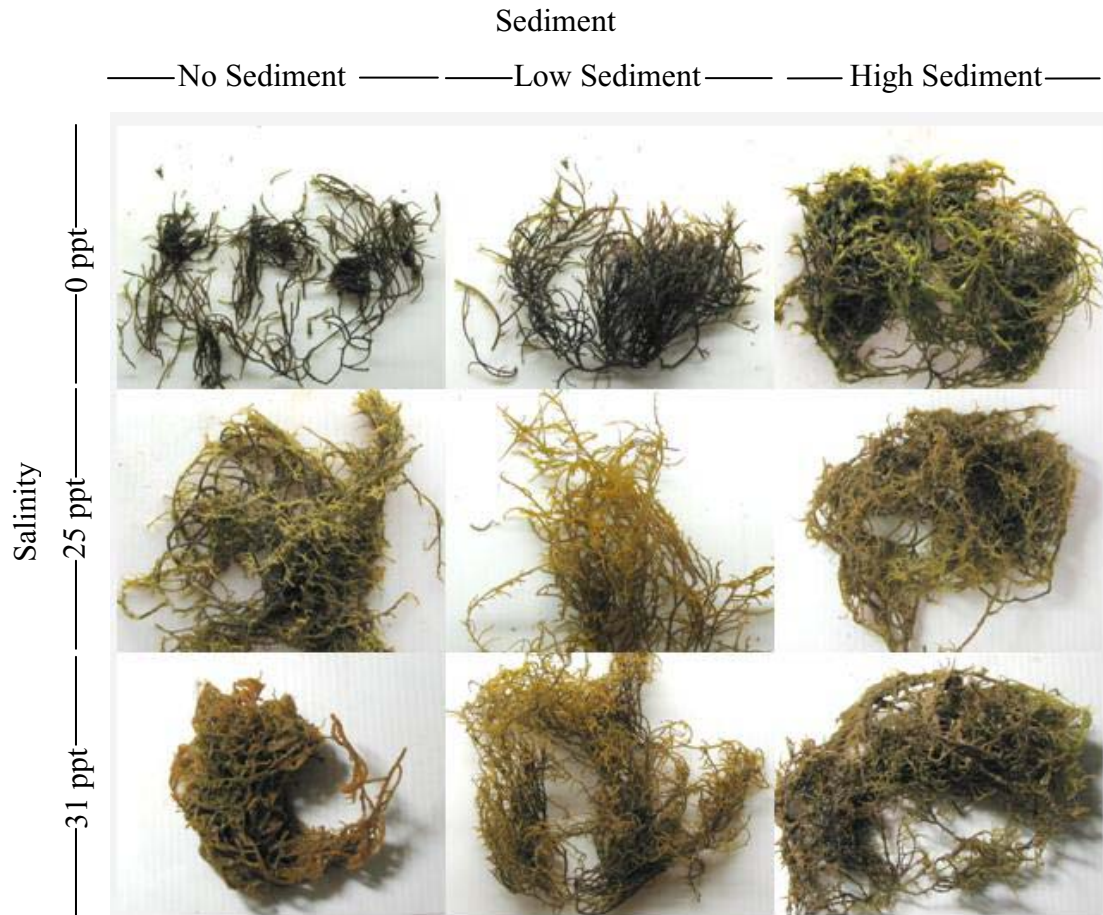

Figure 22. *G. tenuistipitata* after cultured under $1,000 \mu\text{mol photons m}^{-2}\text{s}^{-1}$ of light intensity condition in each salinity and 3 levels of sediment for 20 days.

4. Biomass

There was significant difference in biomass among salinities, light intensities and interactions of the three factors ($P < 0.05$). However, sediment showed no effects on biomass (Table 3). The highest increasing biomass was 137.01 ± 3.63 % in no sediment, 25 ppt and $700 \mu\text{mol photon m}^{-2}\text{s}^{-1}$ condition, while weight was decreased, -15.83 ± 2.26 %, in no sediment, 0 ppt and $700 \mu\text{mol photon m}^{-2}\text{s}^{-1}$ condition (Figure 23). The biomass in fresh water (0 ppt) was lower than other salinity and become lowest when combined with high light intensity condition ($400\text{-}1,000 \mu\text{mol photon m}^{-2}\text{s}^{-1}$) in no sediment condition.

Stepwise multiple regression revealed that there was positive correlations between biomass and salinity and light intensity ($r^2 = 0.845$, $P < 0.05$) (Table 4).

Table 3. The difference of mean biomass production of *G. tenuistipitata* in salinity, light intensity and sediment conditions.

Source of variation	<i>df</i>	MS	<i>F</i>	P
Between subjects				
Sediment	2	65.513	0.389	0.679
Light	3	6652.563	39.490	0.000
Salinity	2	42098.893	249.899	0.000
Sediment*Light	6	817.968	4.855	0.000
Sediment*Salinity	4	4684.552	27.807	0.000
Light*Salinity	6	3179.999	18.876	0.000
Sediment*Light*Salinity	12	1382.790	8.208	0.000
Error	72	168.464		

Table 4. Partial correlations coefficients of environmental parameters on biomass, pigment contents, photosynthesis, respiration and agar of *G. tenuistipitata*.

Variables	Partial correlations coefficients			F	sig	R ²
	Salinity	Light Intensity	Sediment			
Biomass (%WG)	0.776	0.472	-	289.100	0.000	0.845
Pigment contents (mg g ⁻¹ FW)	PE	-	-	-	-	-
	Chl <i>a</i>	- 0.312	- 0.315	11.449	0.000	0.179
Photosynthesis rate (mg O ₂ g d wt ⁻¹ h ⁻¹)	PC	-	0.195	6.397	0.002	0.109
	Short	0.263	-	5.665	0.005	0.133
Respiration rate (mg O ₂ g d wt ⁻¹ h ⁻¹)	Long	-	-	-	-	-
	Short	-	-	-	-	-
Agar (%DW)	Long	-	0.262	8.327	0.000	0.137
	Short	- 0.273	0.210	7.533	0.000	0.179

* PE; Phycoerythrin, Chl *a*; Chlorophyll *a*, PC; Phycocyanin, Short; Short period cultivation, Long; Long period cultivation.

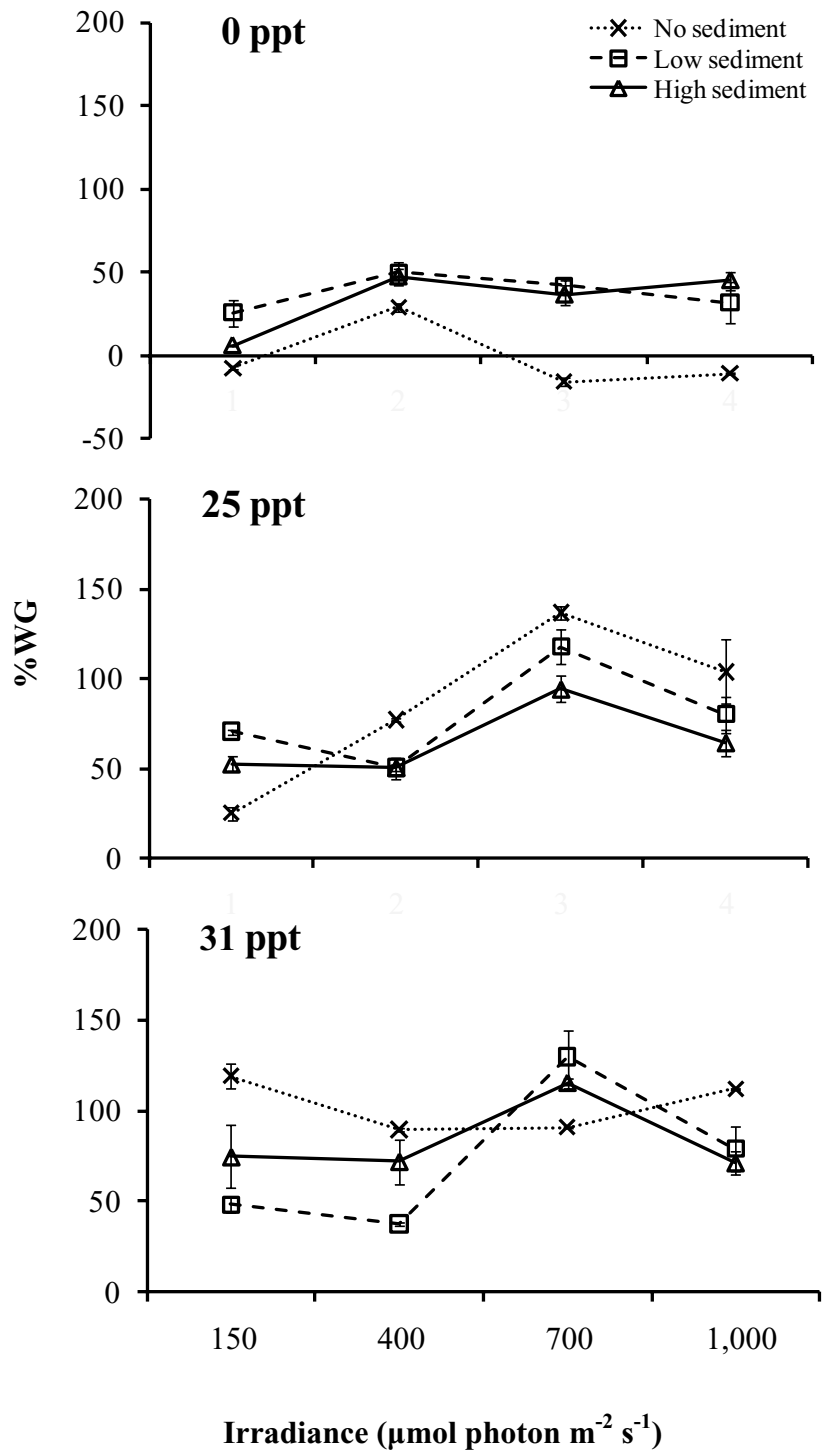

Figure 23. Mean biomass of *G. tenuistipitata* in each culturing after 20 days cultured. The error bars are standard error. (n=108)

5. Pigment content

5.1 Chlorophyll *a*

There were significant differences in chlorophyll *a* content among salinities, light intensities, sediments and interactions of the three factors ($P < 0.05$) (Table 5). The highest chlorophyll *a* content was $0.211 \pm 0.02 \text{ mg g}^{-1} \text{ FW}$, in no sediment, 0 ppt and $700 \mu\text{mol photon m}^{-2}\text{s}^{-1}$ condition. The chlorophyll *a* content then decreased to $0.02 \pm 0.002 \text{ mg g}^{-1} \text{ FW}$ in low sediment, 0ppt and $150 \mu\text{mol photon m}^{-2}\text{s}^{-1}$ condition. There was high the chlorophyll *a* content when cultured in low light condition ($150 \mu\text{mol photon m}^{-2}\text{s}^{-1}$) at low salinity condition and the thallus also looked darker (Figure 24).

Stepwise multiple regression showed that there was a negative correlation between chlorophyll *a* and salinity and light intensity ($r^2 = 0.179$, $P < 0.05$) (Table 4).

Table 5. The difference of mean chlorophyll *a* content of *G. tenuistipitata* in salinity, light intensity and sediment conditions.

Source of variation	<i>df</i>	MS	<i>F</i>	P
Between subjects				
Sediment	2	0.034	29.992	0.000
Light	3	0.042	37.097	0.000
Salinity	2	0.054	47.588	0.000
Sediment*Light	6	0.012	10.967	0.000
Sediment*Salinity	4	0.028	24.670	0.000
Light*Salinity	6	0.013	11.809	0.000
Sediment*Light*Salinity	12	0.013	11.872	0.000
Error	72	0.001		

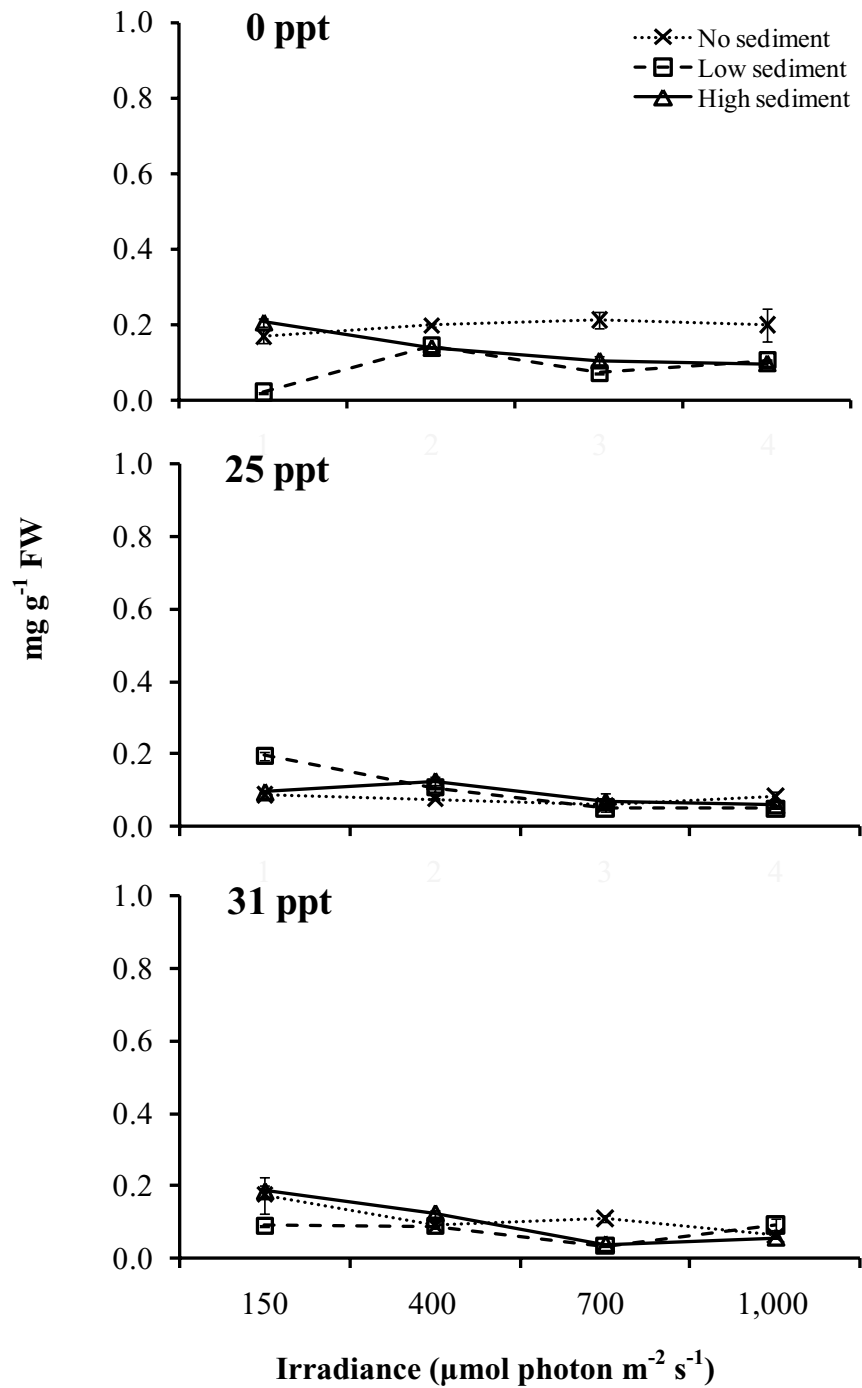

Figure 24. Changes in chlorophyll *a* content of *G. tenuistipitata* when cultured under different salinity, light intensity and sediment conditions for 20 days. The error bars are standard error. (n=108)

5.2 Phycoerythrin

There were significant differences in phycoerythrin among sediments and interactions of the three factors ($P < 0.05$), whereas salinity, light intensity showed no effects (Table 6). The phycoerythrin content was increased to $0.84 \pm 0.04 \text{ mg g}^{-1}\text{FW}$ in high sediment, 31 ppt and $150 \mu\text{mol photon m}^{-2}\text{s}^{-1}$ condition and then decreased to $0.018 \pm 0.003 \text{ mg g}^{-1}\text{FW}$ in low sediment, 0 ppt and $150 \mu\text{mol photon m}^{-2}\text{s}^{-1}$ condition. The phycoerythrin content was higher than Chlorophyll *a* and phycocyanin contents when cultured in low light intensity condition ($150 \mu\text{mol photon m}^{-2}\text{s}^{-1}$) (Figure 25).

Stepwise multiple regression revealed that there was no relationship between phycoerythrin content and salinity, light intensity and sediment (Table 4).

Table 6. The difference of mean phycoerythrin content of *G. tenuistipitata* in salinity, light intensity and sediment conditions.

Source of variation	<i>df</i>	MS	<i>F</i>	P
Between subjects				
Sediment	2	0.368	48.460	0.000
Light	3	0.017	2.286	0.086
Salinity	2	0.002	0.223	0.801
Sediment*Light	6	0.084	11.037	0.000
Sediment*Salinity	4	0.038	4.963	0.001
Light*Salinity	6	0.051	6.745	0.000
Sediment*Light*Salinity	12	0.067	8.848	0.000
Error	72	0.008		

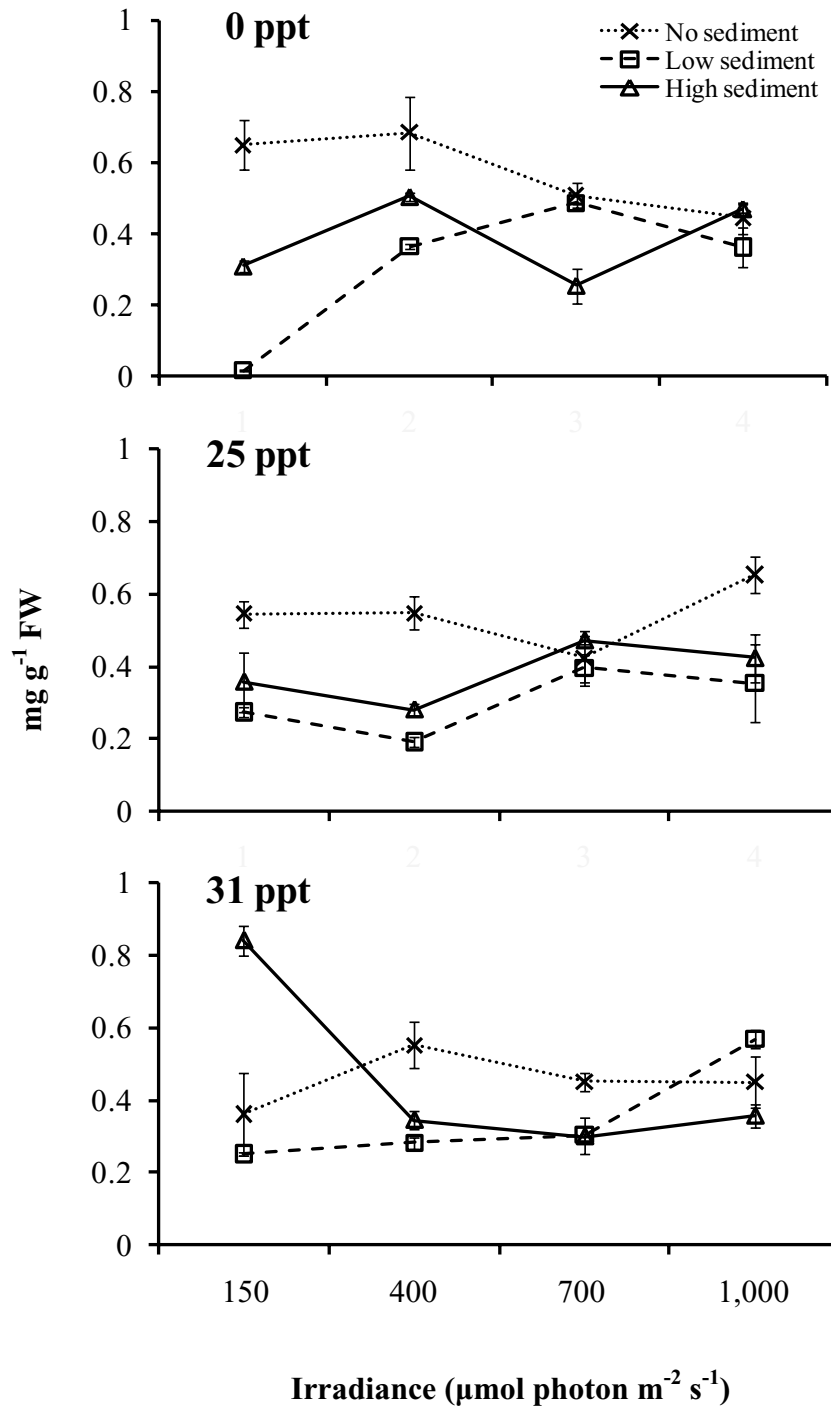

Figure 25. Changes in phycoerythrin content of *G. tenuistipitata* when cultured under different salinity, light intensity and sediment conditions for 20 days. The error bars are standard error. (n=108)

5.3 Phycocyanin

There were significant differences in phycocyanin content among light intensities, sediments and interactions of the three factors ($P < 0.05$), whereas salinity showed no effects (Table 7). The highest phycocyanin content was $0.341 \pm 0.05 \text{ mg g}^{-1} \text{FW}$ when cultured in high sediment, 31 ppt and $150 \mu\text{mol photon m}^{-2} \text{s}^{-1}$ condition. The lowest phycocyanin content was $0.014 \pm 0.002 \text{ mg g}^{-1} \text{FW}$ when cultured in low sediment, 0 ppt and $150 \mu\text{mol photon m}^{-2} \text{s}^{-1}$ condition. In addition, the phycocyanin content increased when cultured in low light intensity condition ($150 \mu\text{mol photon m}^{-2} \text{s}^{-1}$) combined with low salinity and high sediment condition (Figure 26).

Stepwise multiple regression revealed that there was a negative correlation between phycocyanin content and light intensity, and a positive correlation with sediment ($r^2 = 0.109$, $P < 0.05$) (Table 4).

Table 7. The difference of mean phycocyanin content of *G. tenuistipitata* in salinity, light intensity and sediment conditions.

Source of variation	df	MS	F	P
Between subjects				
Sediment	2	0.031	22.498	0.000
Light	3	0.020	14.536	0.000
Salinity	2	0.000	0.125	0.883
Sediment*Light	6	0.017	12.674	0.000
Sediment*Salinity	4	0.014	10.100	0.000
Light*Salinity	6	0.005	3.479	0.004
Sediment*Light*Salinity	12	0.009	6.534	0.000
Error	72	0.001		

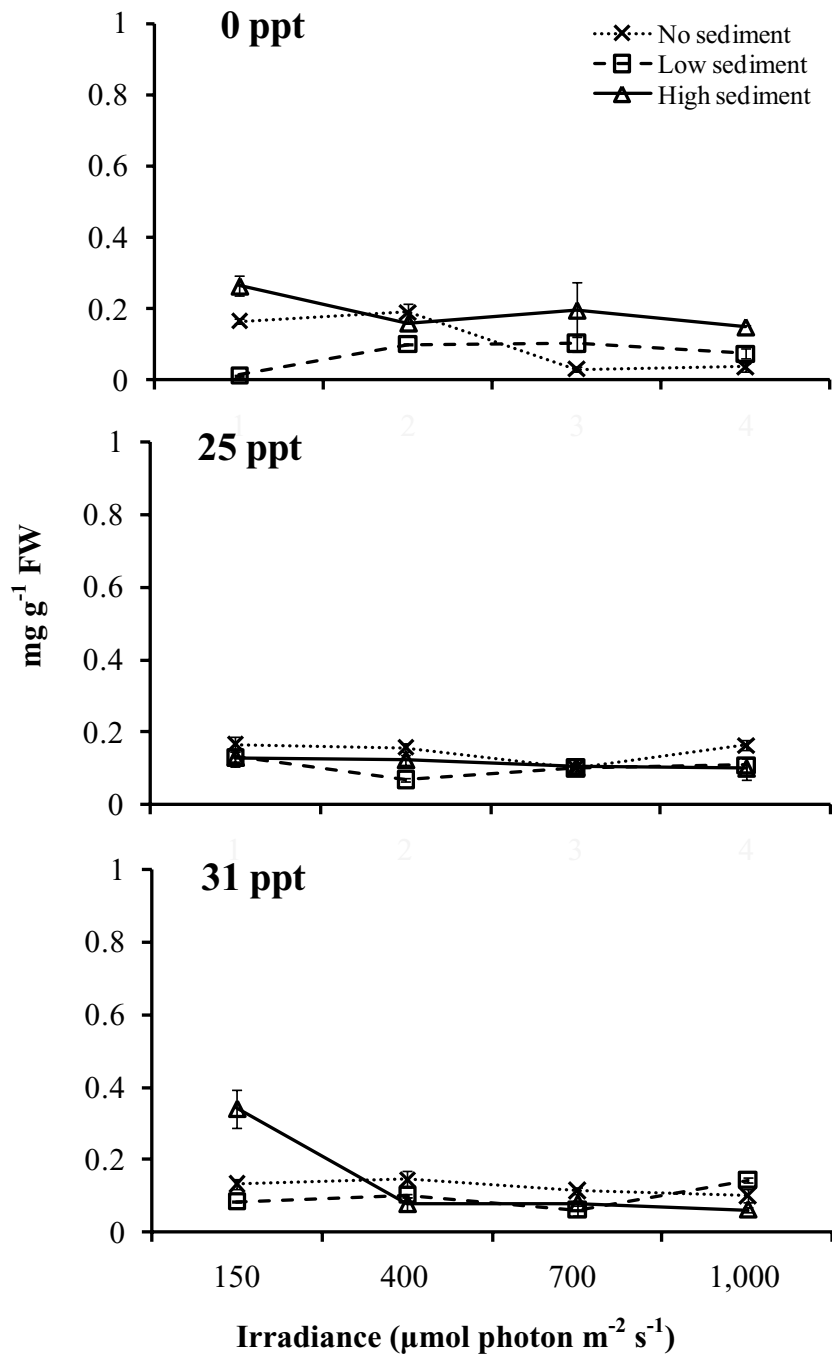

Figure 26. Changes in phycocyanin content of *G. tenuistipitata* when cultured under different salinity, light intensity and sediment conditions for 20 days. The error bars are standard error. (n=108)

6. Photosynthesis

There were no significant differences in net photosynthesis rate among salinities, light intensities, sediments and interactions of the three factors ($P>0.05$) on short term and long term periods experiment. However, salinity and sediment had significant effects on the net photosynthesis rate when cultured on long period ($P<0.05$) (Table 8 and 9).

In short term period cultivation, the highest photosynthesis rate was 161.331 ± 32.638 mg O₂ g d wt⁻¹h⁻¹ cultured in no sediment, 25 ppt and 400 μ mol photon m⁻²s⁻¹ condition and the lowest photosynthesis rate was -27.648 ± 3.568 mg O₂ g d wt⁻¹h⁻¹, when cultured in no sediment, 0 ppt and 150 μ mol photon m⁻²s⁻¹ condition (Figure 27). In long term period cultivation, the highest photosynthesis rates was 60.26 ± 6.71 mg O₂ g d wt⁻¹h⁻¹ when cultured in no sediment, 25 ppt and 700 μ mol photon m⁻²s⁻¹ condition and the lowest was -21.048 ± 4.577 mg O₂ g d wt⁻¹h⁻¹, when cultured in high sediment, 31 ppt and 700 μ mol photon m⁻²s⁻¹ condition (Figure 28).

In short period cultivation, stepwise multiple regression showed that there was a positive correlation between photosynthesis rates and salinity, and negative correlation with sediment ($r^2=0.280$, $P<0.05$) (Table 4). In long period cultivation, stepwise multiple regression showed that there was no correlations.

Table 8. The difference of mean the photosynthesis rates of *G. tenuistipitata* in salinity, light intensity and sediment conditions on short period cultivations (3 days).

Source of variation	<i>df</i>	MS	<i>F</i>	P
Between subjects				
Sediment	2	0.401	2.748	0.075
Light	3	0.310	2.123	0.111
Salinity	2	0.747	5.127	0.010
Sediment*Light	6	0.280	1.924	0.099
Sediment*Salinity	4	0.181	1.238	0.309
Light*Salinity	6	0.081	0.553	0.765
Sediment*Light*Salinity	10	0.440	3.021	0.006
Error	43	0.146		

Table 9. The difference of mean the photosynthesis rates of *G. tenuistipitata* in salinity, light intensity and sediment conditions on long period cultivations (20 days).

Source of variation	<i>df</i>	MS	<i>F</i>	P
---------------------	-----------	----	----------	---

Between subjects				
Sediment	2	1.405	0.361	0.700
Light	3	6.397	1.643	0.200
Salinity	2	0.537	0.138	0.872
Sediment*Light	6	3.917	1.006	0.440
Sediment*Salinity	4	1.689	0.434	0.783
Light*Salinity	6	5.082	1.306	0.285
Sediment*Light*Salinity	6	3.899	1.002	0.442
Error	30	3.892		

Short period cultivation

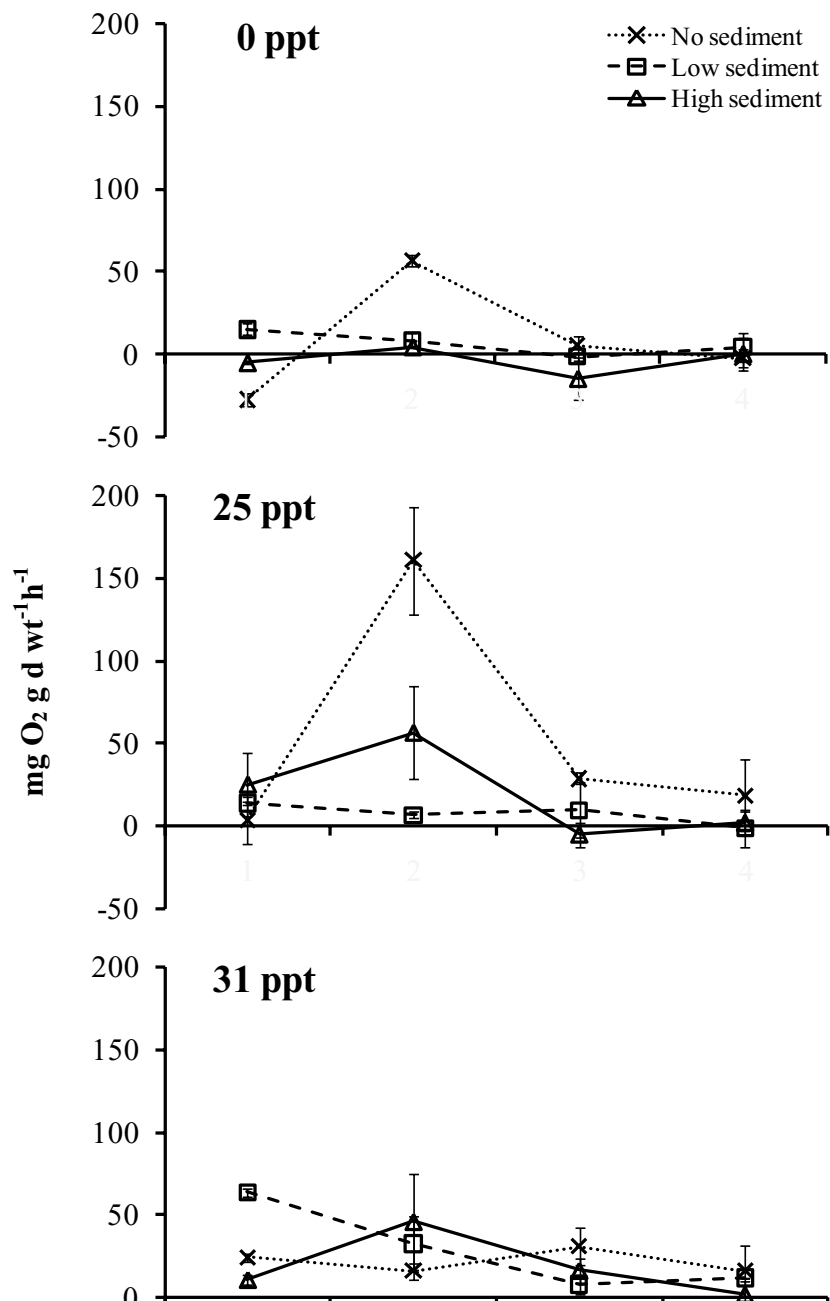

150 400 700 1,000

Irradiance ($\mu\text{mol photon m}^{-2} \text{s}^{-1}$)

Figure 27. Effect of salinity, light intensity and sediment on photosynthesis rates of *G. tenuistipitata* in short period culturing (3 days). The error bars are standard error. (n=108)

Long period cultivation

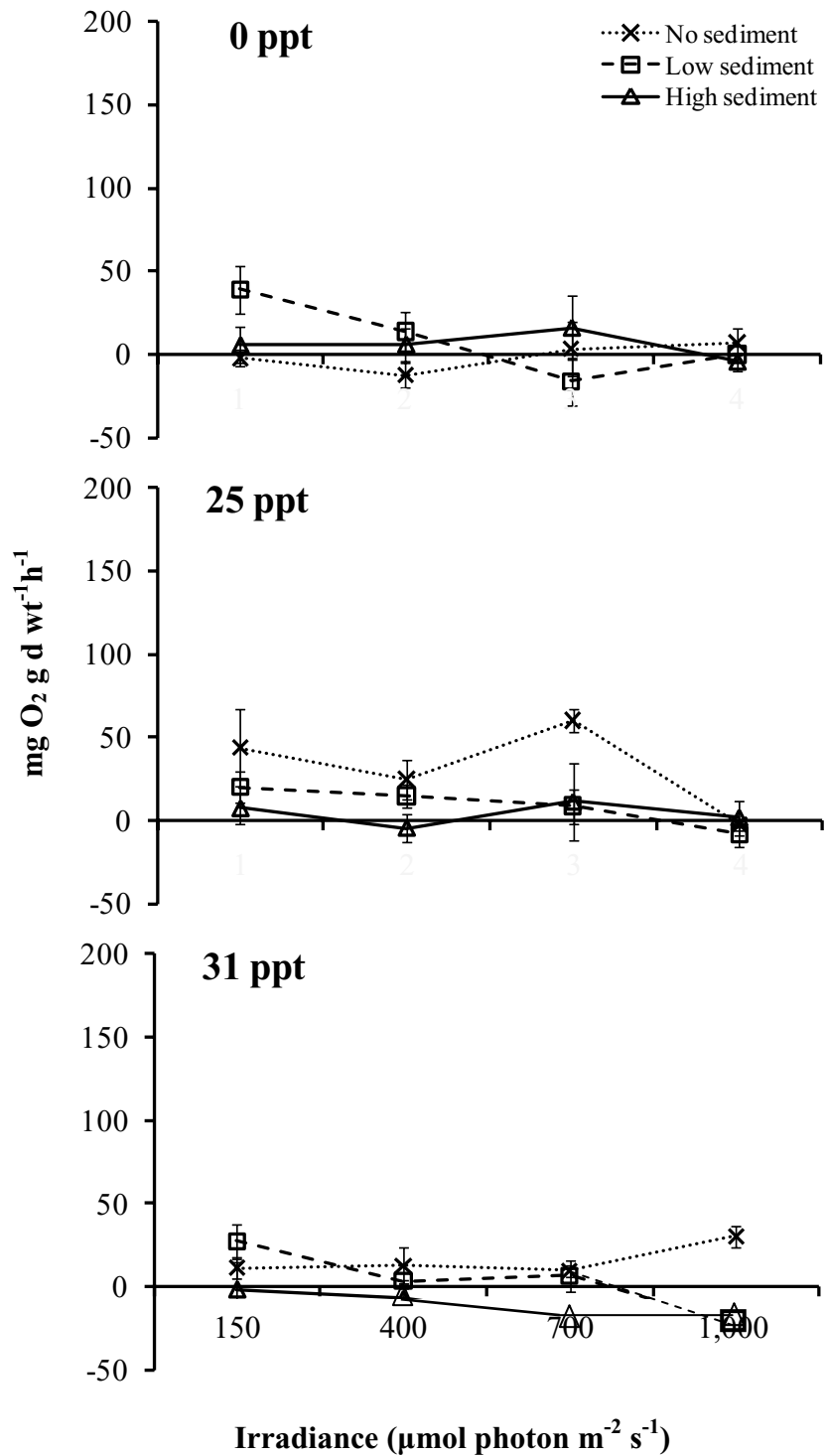

Figure 28. Effect of salinity, light intensity and sediment on photosynthesis rates of *G. tenuistipitata* in long period culturing (20 days). The error bars are standard error. (n=108)

7. Respiration

There was no significant difference in respiration among salinities, light intensities and sediments on both periods of cultivations ($P>0.05$), whereas interaction of light and salinity showed significant effects on the respiration when cultured on long term period ($P<0.05$) (Table 10 and 11).

In short term period cultivation, the highest respiration was 45.91 ± 30.84 mg O₂ g d wt⁻¹h⁻¹, when cultured in low sediment, 25 ppt and 150 μ mol photon m⁻²s⁻¹ condition and the lowest respiration was 0.047 ± 7.04 mg O₂ g d wt⁻¹h⁻¹ when cultured in high sediment, 0 ppt and 1,000 μ mol photon m⁻²s⁻¹ condition (Figure 29). In long term period cultivation, the highest respiration was 43.475 ± 25.075 mg O₂ g d wt⁻¹h⁻¹ when cultured in high sediment, 0 ppt and 700 μ mol photon m⁻²s⁻¹ condition and the lowest respiration was 1.168 ± 12.737 mg O₂ g d wt⁻¹h⁻¹ when cultured in low sediment, 0 ppt and 700 μ mol photon m⁻²s⁻¹ condition (Figure 30).

There was no correlation between respiration and salinities, light intensities and sediments, but in long term cultivation, stepwise multiple regression showed a positive correlation between the respiration and light intensity and sediment ($r^2=0.137$, $P<0.05$) (Table 4).

Table 10. The difference of mean respiration of *G. tenuistipitata* in salinity, light intensity and sediment conditions on short period cultivations (3 days).

Source of variation	<i>df</i>	MS	<i>F</i>	P
Between subjects				
Sediment	2	4.105	2.527	0.113
Light	3	0.918	0.565	0.646
Salinity	2	2.877	1.772	0.204
Sediment*Light	6	1.615	0.994	0.464
Sediment*Salinity	4	1.731	1.066	0.408
Light*Salinity	6	1.624	1.000	0.460
Sediment*Light*Salinity	5	5.087	3.132	0.039
Error	15	1.624		

Table 11. The difference of mean respiration of *G. tenuistipitata* in salinity, light intensity and sediment conditions on long period cultivations (20 days).

Source of variation	<i>df</i>	MS	<i>F</i>	P
Between subjects				
Sediment	2	1,316.408	5.020	0.009
Light	3	799.575	3.049	0.034
Salinity	2	812.218	3.097	0.051
Sediment*Light	6	340.635	1.299	0.269
Sediment*Salinity	4	522.055	1.991	0.105
Light*Salinity	6	211.927	0.808	0.567
Sediment*Light*Salinity	12	369.371	1.409	0.182
Error	72	262.244		

Short period cultivation

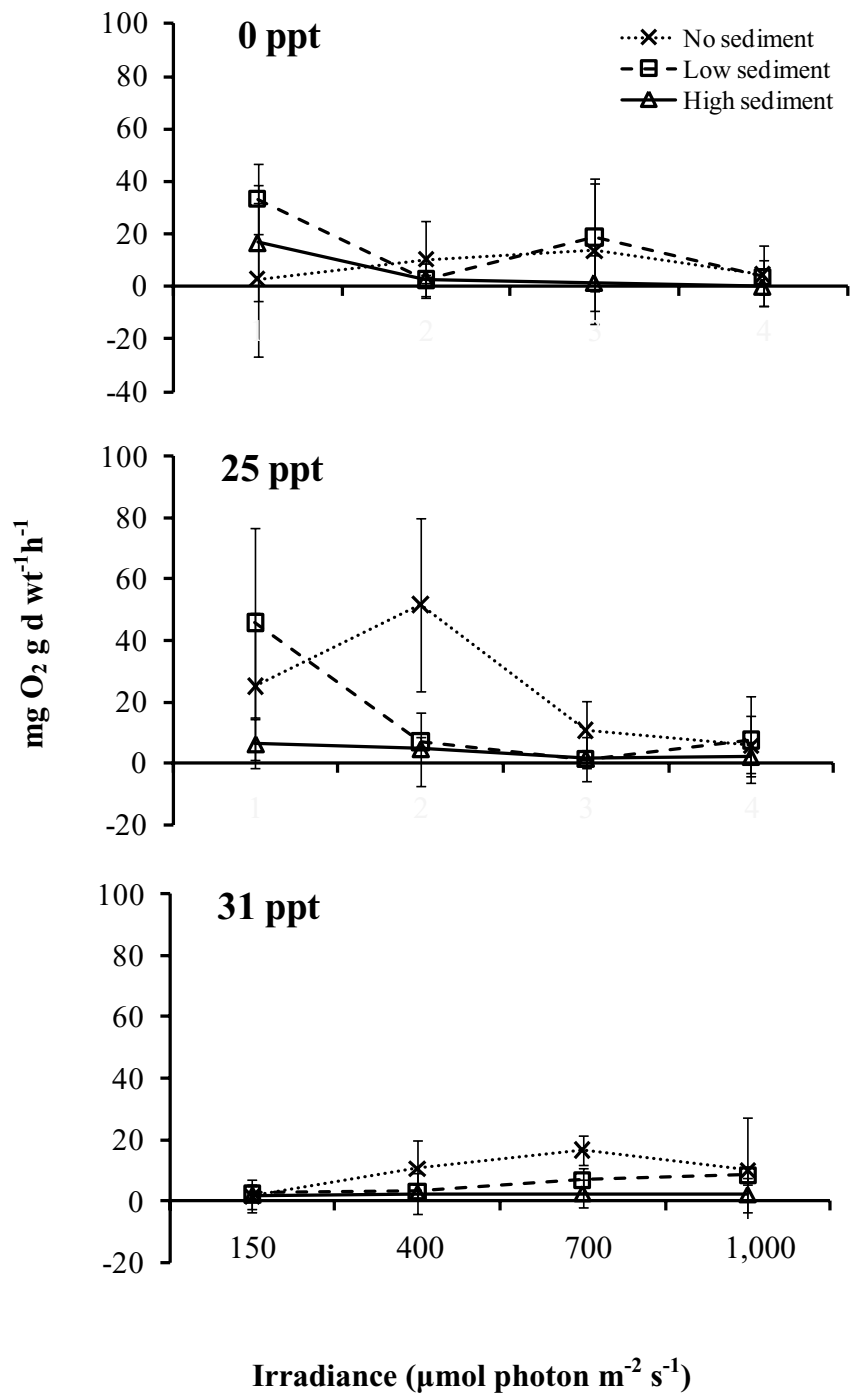

Figure 29. Effect of salinity, light intensity and sediment on respiration of *G. tenuistipitata* in short period culturing (3 days). The error bars are standard error. (n=108)

Long period cultivation

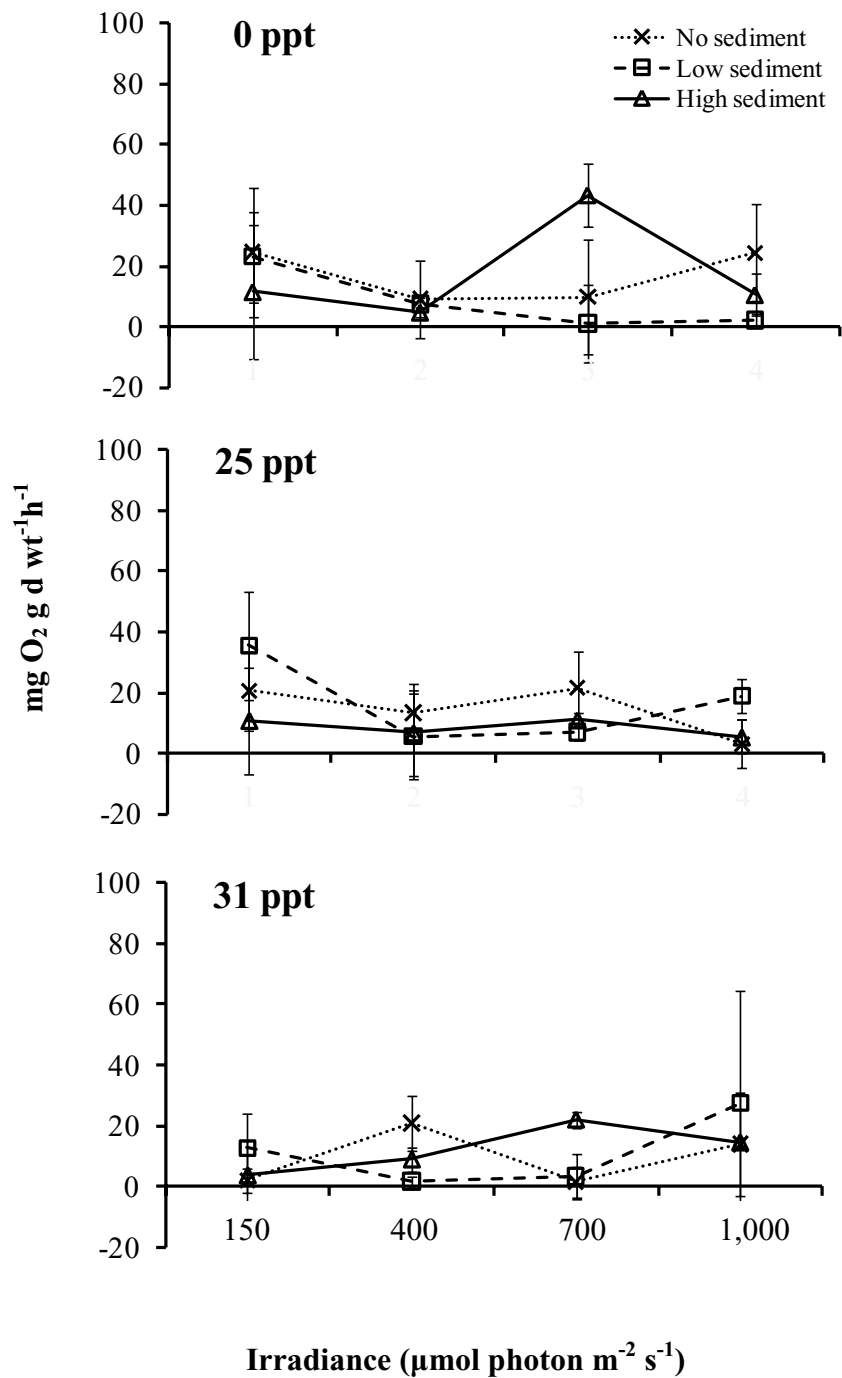

Figure 30. Effect of salinity, light intensity and sediment on respiration of *G. tenuistipitata* in long period culturing (20 days). The error bars are standard error. (n=108)

8. Agar

There was significant difference in agar production among salinities, light intensities, sediments and interactions of the three factors ($P < 0.05$) (Table 12). The highest percentage of agar yield was 24.80 ± 2.96 when cultured in no sediment, 0 ppt and $1,000 \mu\text{mol photon m}^{-2}\text{s}^{-1}$ condition. The lowest percentage of agar yield was 4.00 ± 0.60 when cultured in high sediment, 25 ppt and $150 \mu\text{mol photon m}^{-2}\text{s}^{-1}$ condition (Figure 31). Moreover, the agar production was when cultured in no sediment condition combined with low salinity (0 ppt).

Stepwise multiple regression revealed that there was a positive correlation between agar production and salinity, and a negative correlations with light intensity and sediment ($r^2 = 0.179$, $P < 0.05$) (Table 4).

Table 12. The difference of mean agar production of *G. tenuistipitata* in salinity, light intensity and sediment conditions.

Source of variation	df	MS	F	P
Between subjects				
Sediment	2	6.699	116.221	0.000
Light	3	1.521	26.393	0.000
Salinity	2	2.926	50.756	0.000
Sediment*Light	6	2.443	42.389	0.000
Sediment*Salinity	4	2.646	45.911	0.000
Light*Salinity	6	0.326	5.654	0.000
Sediment*Light*Salinity	12	0.810	14.620	0.000
Error	72	0.058		

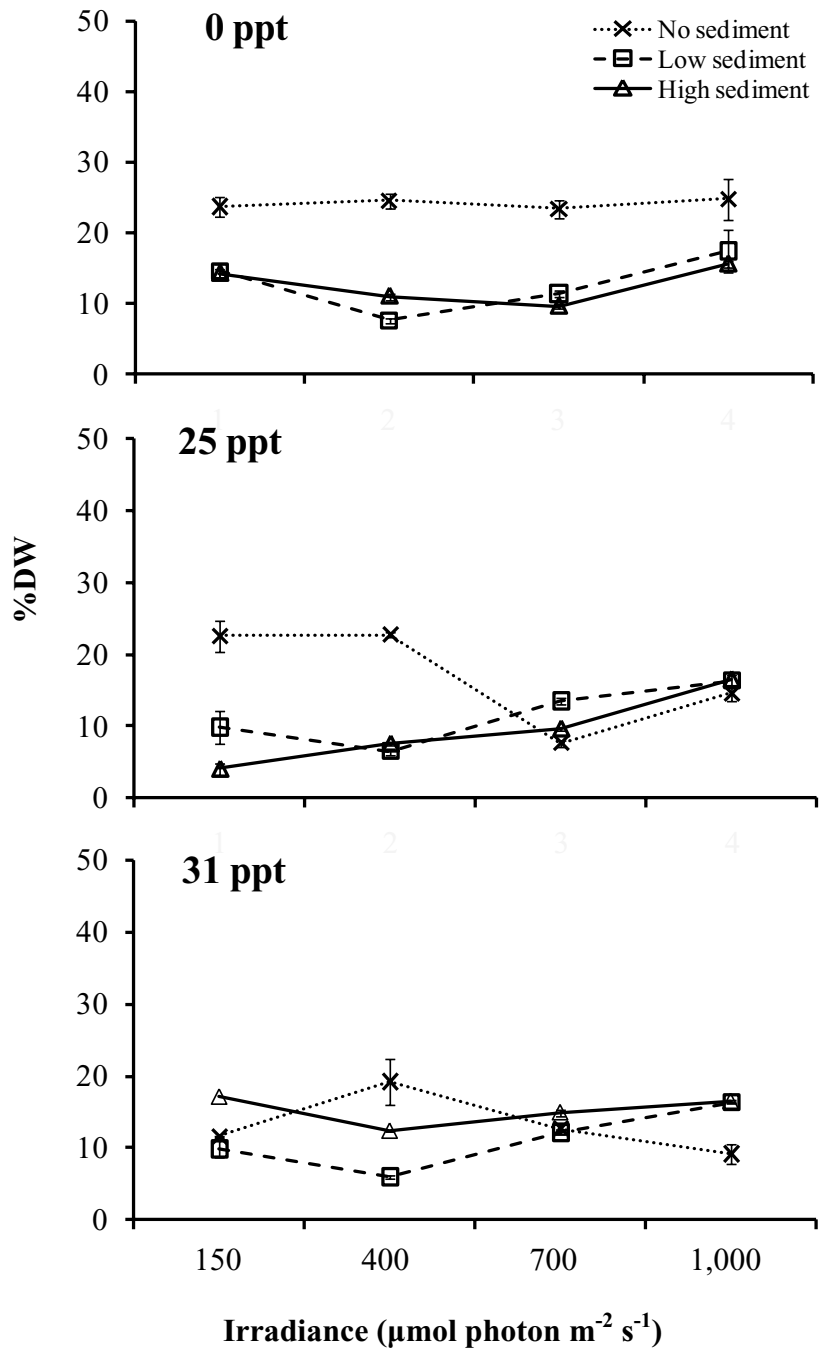

Figure 31. Mean Agar production of *G. tenuistipitata* in each culturing after 20 days cultured. The error bars are standard error. (n=108)

CHAPTER 4

DISCUSSION

There have been numerous studies on physiological responses to combinations of abiotic factors, salinity and light (Israel *et al.*, 1999; Li-hon *et al.*, 2002; Chirapart and Lewmanomont, 2004; Chirapart *et al.*, 2006; Skriptsova and Nabivailo, 2009). This is the first study looking at the effects of the combinations of salinity, light intensity and sediment on biomass, pigments, photosynthesis, respirations and agar production of *Gracilaria tenuistipitata*. These combinations are common for *G. tenuistipitata*, which normally habit in esturaine in many places such as China and the Philippines and also in Pattani Bay, Thailand. Sediment is an additional factor since there are a lot of problems with developments and deforestations in the last decades, which increasing the sedimentation in the habitats. This study revealed that *G. tenuistipitata* showed resilience to stresses under differences in salinity, light intensity and sediment.

Effect of environmental parameters at Koh Yor

This study showed that salinity, light intensity and sediment at Koh Yor were greatly different between seasons. The salinity decreased presumably due to fresh water run off in rainy season (May to July and October to December) and increased in dry season (February to April). The high amount of sediment also accompanied with fresh water run off in rainy season. During rainy season, high loaded sediment from the run off, causing increasing of sedimentation and decreasing of light intensity because of the turbidity. The fine sediment then settled on the bottom during summer months when less water exchanged between inland and sea, which later on cover the algae. During two years observation at Koh Yor, there were many developments around the area, increasing the sediment loaded, which disturbed algae habitat. *G. tenuistipitata* population was strongly influenced by salinity, light intensity and sedimentation respectively.

Combinations of salinity and light intensity strongly affected photosynthesis and respiration which influenced biomass, pigment content and agar production of *G. tenuistipitata*. Salinity was the most important factor driving algae growth production. Light intensity also influenced the photosynthesis and respiration and sediment indirectly cut down the light.

1. Effects of salinity

Salinity is one of the most important chemical factor affecting growth and physiological processes of seaweeds (Lapointe *et al.*, 1984; Dawes *et al.*, 1999). *G. tenuistipitata* showed positively relationship with increasing of salinity, by increasing its growth. In this study, the optimum growth was observed in the salinity range between 25 and 31 ppt. The best condition for the highest daily specific growth rates (% increase in wet weight) is determined at 25 ppt, 6.85 % per day. This was lower than the study by Yongjian *et al.* (2009), showed 10.25% per day at 24 ppt. However, *G. tenuistipitata* could also grow in a very high salinity at 39 ppt (Israel *et al.*, 1999). By contrast, the biomass and photosynthesis rate were lowest at 0 ppt; this is influenced to osmotic pressure; hypo- and hyper salinities have caused significant reduction in growth of many red algae and also *Gracilaria* (Penniman and Mathieson, 1985; Kirst, 1989; Dawes *et al.*, 1999; Wong and Chang, 2000; Phooprong *et al.*, 2007). This is related to the movement of water molecules and ions across the cell membrane required as co-factors in photosynthesis, respiratory rates and changes in shape of pigment contents (Kirst, 1981, 1989; Lapointe *et al.*, 1984; Simon *et al.*, 1999; Skriptsova and Nabivailo, 2009). This also led to changing of chemical structure such as pigments disruption in the photosystem, protein synthesis and storage product (Kirst, 1989).

The decreasing of agar might be the results from inhibited photosynthetic, carbon fixation and stimulated the energy uses for balancing the ion-exchange in lower salinity, decreasing the storage products (floridean starch) in red algae (Macler, 1988; Kirst, 1989; Li-hong *et al.*, 2002). The optimal salinity for growth and agar synthesis of *G. tenuistipitata* (24.80% of DW agar) in this study was at 25 ppt, but by increasing or decreasing salinities, the agar productions would increase; this is to support turgid cells helping with osmotic acclimation and may be

an indicator for acclimatization of stress in algae (Kirst, 1989), which is also clearly shown in this study. This is, however, still unclear since there was degraded of the storage products when cultured at low salinity at 3 ppt for 8 days at 100 $\mu\text{mol photons m}^{-2}\text{s}^{-1}$ (Yu and Pedersen, 1990), thus further study would be needed to provide a better understanding on agar productions.

2. Effects of Light

G. tenuistipitata was tolerant in wide range of light intensity, between 150-700 $\mu\text{mol photon m}^{-2}\text{s}^{-1}$. Increased light intensity promoted biomass but also increased respiration and decreased agar production; pigment contents, on the other hands, were decreased. Generally, the optimal light in this species is 20-300 $\mu\text{mol photons m}^{-2}\text{s}^{-1}$ (Yongjian *et al.*, 2009) but in this study, the maximum biomass was found in rather high light intensity, 700 $\mu\text{mol photon m}^{-2}\text{s}^{-1}$ condition and photoinhibition have also observed at 1,000 $\mu\text{mol photons m}^{-2}\text{s}^{-1}$. Similar to other species, *G. cornea* had the optimum irradiances between 100-800 $\mu\text{mol photons m}^{-2}\text{s}^{-1}$ for growth and photoinhibition occurred above 1,000 $\mu\text{mol photons m}^{-2}\text{s}^{-1}$ (Penninan and Mathieson, 1985; Dawes *et al.*, 1999)

The pigment contents (chlorophyll *a* and phycocyanin) of *G. tenuistipitata* decreased with increasing of light intensity. In this study, there was highest phycoerythrin under low light levels (150 $\mu\text{mol photon m}^{-2}\text{s}^{-1}$), 0.84 mg g^{-1} FW. This was higher than the study by Beer and Levy, (1983) under 140 $\mu\text{mol photon m}^{-2}\text{s}^{-1}$ of light condition, showed 0.65 mg g^{-1} FW. The changes in pigmentation resulting from photoacclimation, there was increased in the number of photosynthetic units or increasing of the size of each photosynthetic unit when cultured under low light intensity for cell metabolism devote of their resources to photosynthetic units synthesis of algae (Beer and Levy, 1983; Lobban *et al.*, 1985; Falkowski and Raven, 1997), in red algae are well known (Beer and Levy, 1983; Carnicas *et al.*, 1999; Godinez-Ortega *et al.*, 2007).

Even though there was no relationship between environmental conditions and photosynthesis rate in this study, the highest of the photosynthesis rate (60.26 $\text{mg O}_2 \text{ g d wt}^{-1}\text{h}^{-1}$) was found at 700 $\mu\text{mol photon m}^{-2}\text{s}^{-1}$ condition, this also caused the increasing of respiration rate. This is known as enhanced post-illumination

respiration when algae exposed to higher light levels thereby accelerating photosynthesis rates, the mitochondrial respiration rate will accelerate (Falkowski and Raven, 1997). Agar decreased when light is increased, which might be caused in process of growth; thus only a few carbohydrates are stored and sometime used (Lobban *et al.*, 1985; Falkowski and Raven, 1997).

3. Effects of sediment

The direct effects of sedimentation on seaweeds were to cut down underwater irradiance, cover and burial or smothering by suspending and depositing of particles (Chapman and Fletcher, 2002; Airoidi, 2003). In this study, seaweed was covered by sediment in all sediment treatments. The photosynthesis and agar production decreased with increasing of sediment whereas phycocyanin and respiration increased, suggested that pigment can adapt to the variations in light intensity which affected by deposition of sediment suspension in other algae (Izagirre *et al.*, 2009), which could also be observed by the dark red thalli. In study, there was highest phycocyanin $0.341 \text{ mg g}^{-1} \text{ FW}$ under low light levels ($150 \mu\text{mol photon m}^{-2} \text{ s}^{-1}$). This was higher than the study by Beer and Levy (1983), showed $0.27 \text{ mg g}^{-1} \text{ FW}$ in $140 \mu\text{mol photon m}^{-2} \text{ s}^{-1}$, which reported that phycoerythrin was nearly 2 times higher than phycocyanin.

Sediment inhibited photosynthetic carbon fixation (Post and Arieli, 1997; Chapman and Fletcher, 2002), which is also known in other algae, *Ulva lactuca*, reducing photosynthetic activity and increasing of mortality under exposure to anoxia and sulfides (Nedergaard *et al.*, 2002). Sediment clearly influences the photosynthesis and respiration rate of *G. tenuistipitata*; and there was slightly increasing of pigments since the sediment was indirectly cut down the light. In a high sediment condition, the sediment covered the algal surface causing anoxic condition, but the results of the sediment was not so crucial since the air pump has been provided throughout the experiment, thus the sediment was likely to stir up most of the time. In contrast, in the field, the sediment accumulation was high, the bottom covered with the sediment deeper than 40 cm; and the anoxic condition was clearly occurred with a strong smell of hydrogen sulfide (H_2S). These conditions were not suitable for growth as well as the recruitment of new juvenile, which reproduction sometime observed

during summer months. The new recruitment, thus, likely to be limited on the soft-bottom but often observed on the fish nets or some other hard substrate within the lagoon.

The critical problem in Songkhla lagoon is salinity and sedimentation, which influenced *G. tenuistipitata* and also other marine organisms, the average of salinity decreased from 18.8 to 14.45 ppt, 23.08 % decreased and the lower salinity period was longer, it is now up to 6 months comparing to only from 2-3 months in 1994. The average of transparency decreased from 0.73 to 0.4 m, 45.20% (Laongsiriwong, 1994; Angsupanich and Rakkheaw, 1997). The developments by building the dam to limit the seawater to come in the lagoon as well as some other developments along and upper the lagoon caused drastic changes in ecosystem, which might cause the extinction of some species if they cannot adapt.

From this study, to culture *G. tenuistipitata* in Songkhla lagoon, it could be divided into 2 crops. Each crop would take 3-4 months and is limited/decided by salinity. 1) The first crop: during the mid of January to the end of April (dry season), salinity 20 to 30 ppt, light intensity $700 \mu\text{mol photon m}^{-2}\text{s}^{-1}$ and 2) The second crop: during the mid of July to the end of September (first rainy season), salinity 17 to 30 ppt, light intensity $400\text{-}700 \mu\text{mol photon m}^{-2}\text{s}^{-1}$.

The first crop is an ideal condition with optimum salinity and high light intensity to increase growth and productivity of *Gracilaria* sp. Since there are a lot of problems with natural farming, the idea of inland culture was introduced. In Pattani Bay, there was a cultivation of *Hydropuntia fisheri* in abandoned shrimp ponds; 2 methods were introduced, bottom scattering, with $9.9\%d^{-1}$ of growth rate and hanging thalli into the rope with $1.6\%d^{-1}$ of growth rate in shrimp ponds situated along the coast of Pattani Bay (Ruangchuay *et al.*, 2006). This might be an ideal opportunity to promote the seaweed cultivation since there are a few abandoned shrimp farms along the coast.

CHAPTER 5

CONCLUSIONS

From this study, it can be concluded that:

1. The environmental factors, salinity, light intensity and sedimentation, influenced growth, pigment contents, photosynthesis, respiration and agar production of *G. tenuistipitata* in Songkhla lagoon.
2. Salinity is the most important factor, driving *G. tenuistipitata* population.
3. *G. tenuistipitata* grow well in a wide range of light intensity between 150-700 $\mu\text{mol photon m}^{-2}\text{s}^{-1}$ and at 400 $\mu\text{mol photon m}^{-2}\text{s}^{-1}$ produced high agar production.
4. Sediment was indirectly cut down underwater irradiance for algae, influenced photosynthesis and respiration rate of *G. tenuistipitata*, and also pigments.

The effects of sedimentation on *G. tenuistipitata* should be further tested and clarify; the causal mechanisms should also be carried out.

CHAPTER 6

REFERENCES

- Airoidi, L. 2003. The effects of sedimentation on rocky coast assemblages. *Oceanography and Marine Biology: an Annual Review*. 41: 161-236.
- Angsupanich, S. and Kuwabara, R. 1999. Distribution of macrozoobenthos in Phawong and U-Taphao Canals flowing into a lagoonal lake, Songkhla, Thailand. *Lakes & Reservoirs : Research and Management*. 4: 1-13.
- Angsupanich, S. and Rakkheaw, S. 1997. Seasonal variation of phytoplankton community in Thale Sap Songkhla, a lagoonal lake in southern Thailand. *Netherlands Journal of Aquatic ecology*. 30(4): 297-307.
- Araño, K. G., Trono Jr, G. C., Montaña, N. E., Hurtadob, A. Q. and Villanueva, R. D. 2000. Growth, agar yield and quality of selected agarophyte species from the Philippines. *Botanica Marina*. 43: 517-524.
- Armisen, R. 1995. World-wide use and importance of *Gracilaria*. *Journal of Applied Phycology*. 7: 231-243.
- Beer, S. and Levy, I. 1983. Effects of photon fluence rate light spectrum composition on growth, photosynthesis pigment relations in *Gracilaria* sp. *Journal of Phycology*. 19: 516-522.
- Bird, K. T. and Ryther, J. H. 1990. Cultivation for *Gracilaria verrucosa* (Gracilariales, Rhodophyta) strain G-16 for agar. *Hydrobiologia*. 204(205): 347-351.
- Buakaew, Y. 2005. Accumulation of Nitrogen and Phosphorus in Songkhla Lake Sediment. Master of Science Thesis in Aquatic Science, Prince of Songkla University.
- Carnicas, E., Jimenez, C. and Niell, F. X., 1999. Effects of changes of irradiance on the pigment composition of *Gracilaria tenuistipitata* var. *liui* Zhang et Xia. *Journal of Photochemistry and Photobiology B: Biology*. 50: 149-158.
- Chapman, A. S. and Fletcher, R. L. 2002. Differential effects of sediments on survival

- and growth of *Fucus serratus* embryos (Fucales, Phaeophyceae). *Journal of Phycology*. 38: 894-903.
- Chirapart, A. and Lewmanomont, K. 2004. Growth and production of Thai agarophyte cultured in natural pond using the effluent seawater from shrimp culture. *Hydrobiologia*. 512: 117-126.
- Chirapart, A., Munkit, J. and Lewmanomont, K. 2006. Changes in yield and quality of agar from the agarophytes, *Gracilaria fisheri* and *G. tenuistipitata* var. *liui* cultivated in Earthen ponds. *Kasetsart Journal (Natural Science)*. 40: 529-540.
- Choi, H. G., Kim, Y. S., Kim, J. H., Lee, S. J., Park, E. J., Ryu J. and Nam, K. W. 2006. Effects of temperature and salinity on the growth of *Gracilaria verucosa* and *G. chorda*, with the potential for mariculture in Korea. *Journal of Applied Phycology*. 18: 269-277.
- Darley, W. M., 1982. *Algal Biology: A Physiological Approach*. In: *Basic Microbiology* Vol. 9, Blackwell Scientific Publications, Oxford: UK.
- Dawes, C. J., Orduna-Rojas, J. and Robledo, D. 1999. Response of the tropical red seaweed *Gracilaria cornea* to temperature, salinity and irradiance. *Journal of Applied Phycology*. 10: 419-425.
- Department of Fisheries, Thailand. 2005. Production of *Gracilaria fisheri* in Pattari Province. (www.fisheries.go.th)
- Ekman, P., Yu, S. and Pedersen, M. 1991. Effects of altered salinity, darkness and algal nutrient status on floridoside and starch content, α -galactosidase activity and agar yield of cultivated *Gracilaria sordida*. *British Phycological Journal*. 26: 123-131.
- Falkowski, P. G. and Raven, J. A. 1997. *Aquatic photosynthesis*. Blackwell Science: New York.
- Food and Agriculture Organization of the United Nations (FAO). 1990. Training manual on *Gracilaria* culture and seaweed processing in China. <http://www.fao.org/docrep/field/003/AB730E/AB730E00.html/> (accessed 11/9/2004).
- Food and Agriculture Organization of the United Nations (FAO) and Network of

- Aquaculture Centre in Asia and the Pacific (NACA). 1996. Regional study and workshop on the taxonomy, ecology and processing of economically important red seaweeds. NACA Environment and Aquaculture Development Series No. 3
- Friedlander M. and Levy I. 1995. Cultivation of *Gracilaria* in outdoor tanks and ponds. *Journal of Applied Phycology*. 7(3): 315-324.
- Godinez-Ortega, J. L., Snoeijs, P., Robledo, D., Freile-Pelegri, Y. and Pedersén, M. 2008. Growth and pigment composition in the red alga *Halymenia floresii* cultured under different light qualities. *Journal of Applied Phycology*. 20: 253-260
- Guiry, M. D. and Guiry, G. M. 2010. AlgaeBase. World-wide electronic publication, National University of Ireland, Galway.
http://www.algaebase.org/search/species/detail/?species_id=60396/
(accessed 17/4/2009)
- Hong, D. D., Hien, H. M. and Son, P. N. 2007. Effect of irradiation on the protein profile, protein content, and quality of agar from *Gracilaria asiatica* Zhang et Xia (Rhodophyta). *Journal of Applied Phycology*. 19: 809-815.
- Israel, A., Martinez-Goss, M., and Friedlander, M. 1999. Effect of salinity and pH on growth and agar yield of *Gracilaria tenuistipitata* var. *liui* in laboratory and outdoor cultivation. *Journal of Applied Phycology*. 11: 543-549.
- Izagirre O., Serra A., Guasch H. and Elosegi A. 2006. Effects of sediment deposition on periphytic biomass, photosynthetic activity and algal community structure. *The Science of the total environment*. 407(21): 5694-5700
- Jeffrey, S. W. and Humphrey, G. F. 1975. New spectrophotometric equations for determining chlorophyll *a*, *b*, *c* in higher plants, algae and natural phytoplankton. *Biochemistry and Physiology. Pflanzen*. 167: 191-194.
- Kakita, H. and Kamishima, H. 2006. Effects of Environmental Factors and Metal Ions on Growth of the Red Alga *Gracilaria chorda* Holmes (Gracilariales, Rhodophyta). *Journal of Applied Phycology*. 18: 469-474.
- Kirst, G. O. 1981. Photosynthesis and respiration of *Griffithsia monilis* (Rhodophyceae): effect of light, salinity, and oxygen. *Planta*. 151: 281-288.
- Kirst, G. O. 1989. Salinity tolerance of eukaryotic marine algae. *Annual Review*

- of Plant Physiology and Plant Molecular Biology. 40: 21-53.
- Koch, E. W. and Lawrence, J. 1987. Photosynthetic and respiratory response to salinity changes in the red alga *Gracilaria verrucosa*. *Botanica Marina*. 30: 327-329.
- Kursar, T. A., Vander, M. J. and Alberte, R. S. 1983. Light-harvesting system of the red alga *Gracilaria tikvahiae*. I. Biochemical analysis of pigment mutations. *Plant Physiology*. 73(2): 353-360.
- La-onsiriwong, N. 1994. Nutrient Limitation of Phytoplankton Biomass in Songkhla Lake. Master of Science Thesis in Environmental Management, Prince of Songkla University, Thailand.
- Lapointe, B. E., Rice D. L. and Lawrence, J. M. 1984. Responses of photosynthesis, respiration, growth and cellular constituents to hypo-osmotic shock in the red alga *Gracilaria tikvahiae*. *Biochemistry and Physiology*. 77(1): 127-132.
- Lee T. M., Chang, Y. C. and Lin Y. H. 1999. Differences in physiological responses between winter and summer *Gracilaria tenuistipitata* (Gigartinales, Rhodophyta) to varying temperature. *Botanical Bulletin of Academia Sinica*. 49: 93-100.
- Lee, R. E. 1999. *Phycology*. The United Kingdom at the University Press, Cambridge: UK.
- Lewmanomont, K. and Ogawa, H. 1995. *Common Seaweeds and Seagrasses of Thailand*. Intergrated Promotion Technology Co., Ltd, Thailand.
- Li-hong, H., Madeline, W., Pei-yuan, Q. and Ming-yuan, Z. 2002. Effects of co-culture and salinity on the growth and agar yield of *Gracilaria tenuistipitata* var *liui* Zhang Et Xia. *Chinese Journal of Oceanology and Limnology*. 20(4): 365-370.
- Lobban, C. S., Harrison, P. J. and Duncan, M. J. 1985. *The physiological ecology of seaweeds*, Cambridge University Press: New York.
- Macler, B. A. 1988. Salinity effects on photosynthesis, carbon allocation and nitrogen assimilation in the red alga, *Gelidium coulteri*, *Plant Physiology*. 88: 690-694.
- Marinho-Soriano, E. 1999. Biomass and agar yield of *Gracilaria bursa-pastoris* in a Mediterranean lagoon. *Seaweed research and utilisation*. 21(1-2): 1-8.

- Marinho-Soriano, E. 2001. Agar polysaccharides from *Gracilaria* species (Rhodophyta, Gracilariaceae). *Journal of Biotechnology* 89: 81-84.
- Marinho-Soriano, E. and Bourret, E. 2003. Effects of season on the yield and quality of agar from *Gracilaria* species (Gracilariaceae, Rhodophyta). *Bioresource Technology* 90: 329-333.
- Marinho-Soriano, E., Moreira, W. S. C. and Carneiro, M. A. A. 2006. Some aspects of the growth of *Gracilaria birdiae* (Gracilariales, Rhodophyta) in an estuary in Northeast Brazil. *Aquaculture International*. 14: 327-336.
- McHugh, D. J. 2003. A guide to the seaweed industry. FAO Fisheries Technical Paper No 441.: FAO.
- Nedergaard, R. I., Risgaard-Peterson, N. and Finster, K. 2002. The importance of sulfate reduction associated with *Ulva lactuca* thalli during decomposition: a mesocosm experiment. *Journal of Experimental Marine Biology and Ecology*. 275: 15-29.
- Office of natural resources and environmental policy and planning, Thailand. 2004
- Panapitukkul, N., Pengnoo, A., Siriwong C. and Chatupote W. 2005. Hydrogeomorphological controls on groundwater quality in the Rattaphum catchment (Songkhla Lake Basin), Thailand. *Journal of Water, Air, & Soil Pollution: Focus*. 5(1-2): 149-163.
- Penniman, C. A. and Mathieson, A. C. 1985. Photosynthesis of *Gracilaria tikvahiae* MacLachlan (Gigartinales, Rhodophyta) from the Great bay Estuary, New Hampshire. *Botanica Marina*. 28: 427-435.
- Perez, R. and Barbaroux, O. 1996. Cultivation and uses of *Gracilaria*. In: Report on a Regional Study and Workshop on the Taxonomy, Ecology and Processing of Economically Important Red Seaweeds / FAO.: Bangkok (Thailand).
- Phooprong, S., Ogawa, H. and Hayashizaki, K. 2007. Photosynthetic and respiratory Responses of *Gracilaria salicornia* (C. Agardh) Dawson (Gracilariales, Rhodophyta) from Thailand and Japan. *Journal of Applied Phycology*. 20(5): 743-750.
- Post, A. F. and Arieli, B. 1997. Photosynthesis of *Prochlorothrix hollandica* under sulfide-rich anoxic conditions. *Applied and Environmental Microbiology*. 63: 3507-3511.

- Prathep, A., Marrs, R. H. and Norton, T. A. 2003. Spatial and temporal variations in sediment accumulation in an algal turf and their impact on associated fauna. *Marine Biology*. 142: 381-390.
- Raika, S. V. Iima, M. and Fujita, Y. 2001. Effect of temperature, salinity and light intensity on the growth of *Gracilaria* spp. (Gracilariales, Rhodophyta) from Japan, Malaysia and India. *Indian Journal of Marine Sciences*. 30: 98-104.
- Ruangchuay, R., Luangthuvapranit, C., Petchsupa, N., Benjama, O. and Masniyom, P. 2006. Culture of Pom Nang Seaweeds (*Gracilaria* spp.) as an Alternative Career for the Local Fishermen in Pattani Bay, Pattani Province. TRF.: Thailand.
- Simon, C., Gall, E. A., Levavasseur, G. and Deslandes, E. 1999. Effects of short-term variations of salinity and temperature on the photosynthetic response of the red alga *Grateloupia doryphora* from Brittany (France). *Botanica Marina* 42: 437-440.
- Skriptsova, A. V. and Nabivailo, Y. V. 2009. Comparison of three gracilarioids: growth rate, agar content and quality. *Journal of Applied Phycology*. 21: 443-450.
- Wong, S. L. and Chang, J. 2000. Salinity and light effects on growth, photosynthesis, and respiration of *Grateloupia filicina* (Rhodophyta). *Aquaculture*. 182: 387-395.
- Yongjian, X., Wei, W. and Jianguang, F. 2009. Effects of salinity, light and temperature on growth rates of two species of *Gracilaria* (Rhodophyta). *Chinese Journal of Oceanology and Limnology*. 27(2): 350-355.
- Yu, S. and Pedersen, M. 1990. The effect of salinity changes on the activity of α -galactosidase of the red algae *Gracilaria sordida* and *G. tenuistipitata*. *Botanica Marina*. 33: 385-391.

Appendix

Appendix 1. The relationship between underwater light intensity ($\mu\text{mol photons m}^{-2}\text{s}^{-1}$) and total suspended solids (mg/l)

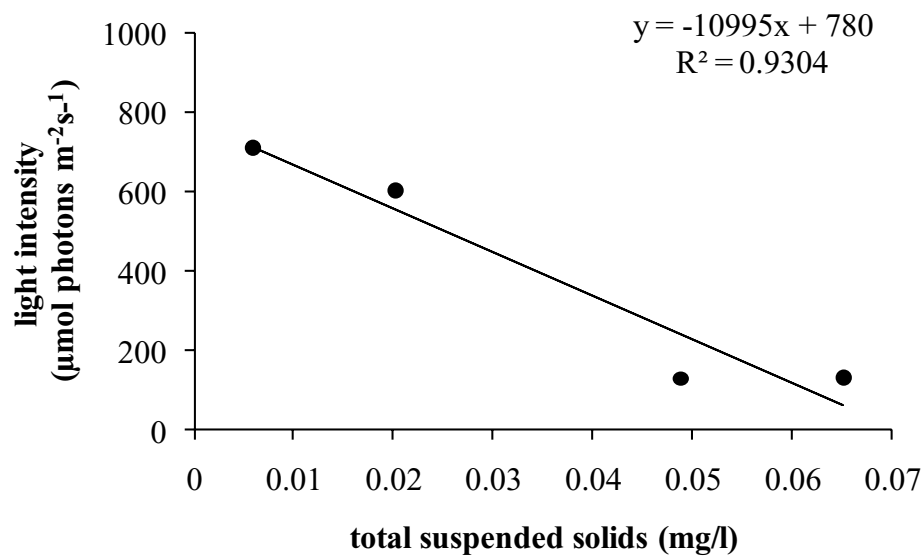

Appendix 2. Water quality at Thalesap Songkhla during January 2006 to December 2007.

Year	Round	Station	TP (mg/l)	NO ₃ (mg/l)	NO ₂ (mg/l)	NH ₃ (mg/l)
2006	1	SK12	-	0.16	0.01	0.15
	2	SK12	-	0.12	0.01	0.09
	3	SK12	-	0.12	0.01	0.09
2007	1	SK12	0.28	0.06	-	0.04
	2	SK12	0.28	0.06	-	0.04
	3	SK12	0.28	0.06	-	0.04

* SK12 = Koh Yor

(Data from: Inland Water Quality Information System)

VITAE

Name Mr. Chaloeiphon Bunsom

Student ID 4822018

Educational Attainment

Degree	Name of Institution	Year of Graduation
B. Sc. (Bioproduction)	Prince of Songkla University	2005

Scholarship Awards during Enrolment

TRF/BRT Spatial program for Biodiversity Research and Training grant BRT T_351120.

List of Publication and Proceeding

Chaloeiphon, B. and Prathep, A. Effects of salinity, light intensity and sediment on growth, pigments, agar production and reproduction in *Gracilaria tenuistipitata* C.F. Chang & B.M. Xia at Koh Yor, Songkhla lagoon, Songkhla Province, Thailand. (In preparation)