

Appendix A

Tests of Mechanical Properties of Wood

A-1. Control of Moisture Control and Temperature

- **Control of Moisture Content**

The seasoned sticks, whether kiln-dried or air-dried, preferably should be stored in a room having controlled temperature and humidity ($20\pm 2^{\circ}\text{C}$ and $65\pm 3\%$ relative humidity) before test to reduce the moisture gradient within the material, and to bring the material into equilibrium, which will be approximately 12% moisture content for most specimens.

Sticks test in the air-dry condition shall be brought practically to constant weight before test. Should any changes in moisture content occur during final preparation specimens, of specimens shall be reconditioned before test to constant weight under conditions $20\pm 2^{\circ}\text{C}$ and $65\pm 3\%$ relative humidity. Tests shall be carried out in such manner that large change in moisture content will not occur. To prevent such changes, it is desirable that the testing room and rooms for preparation of test specimens have some means of humidity control.

- **Control of Temperature**

Independent of the effect on strength of the moisture content of the test specimens as influenced by temperature, is the significant effect of temperature itself on the mechanical properties. The specimens when tested shall be at a temperature of $20\pm 2^{\circ}\text{C}$.

A-2. Moisture Determination

- **Selection**

The sample for moisture determination of each test specimen shall be selected as herein before described for each test.

- **Weighing**

Immediately after obtaining the moisture sample, all loose splinters shall be removed and the sample shall be weighed.

- **Drying**

The moisture samples shall be open piled in an oven and dried at a temperature of $103\pm 2^{\circ}\text{C}$ until approximately constant weight is attained, after which the oven-dry weight shall be determined.

- **Moisture Content**

The loss in weight, expressed in percentage of the oven-dry weight as above determined, shall be considered the moisture content of the specimen.

A-3. Specific Gravity

- **Procedure**

Obtain both specific gravity and moisture content determinations on the same specimen. Weigh the specimen when green and determine the volume. Dry in an oven and dry at $103\pm 2^{\circ}\text{C}$ until approximately constant weight is reached. After oven drying, weigh the specimen.

- **Calculation of Results**

The results is given in term Specific Gravity, SG and can be expressed as:

$$\text{SG} = \frac{W_0}{V_t}$$

Where

W_0 = Weight after dried
 V_t = Volume during testing

A-4. Compression Parallel to Grain

- **Size of Specimen**

The compression-parallel-to-grain tests shall be made on nominal 20 by 20 by 60 mm specimens. The actual cross-section dimensions and the length shall be measured. Measurements of test specimens shall be measured by caliper (read 2 position decimal).

- **Loading Method**

The specimen shall be placed in compression parallel to grain. Special care shall be used in preparing the compression-parallel to grain test specimens to ensure that the end grain surface will be parallel to each other and at right angles to the longitudinal. If deemed necessary, at least on platen of the testing machine shall be equipped with a spherical bearing to obtain uniform distribution of load over the ends of the specimen. (See Figure A-1)

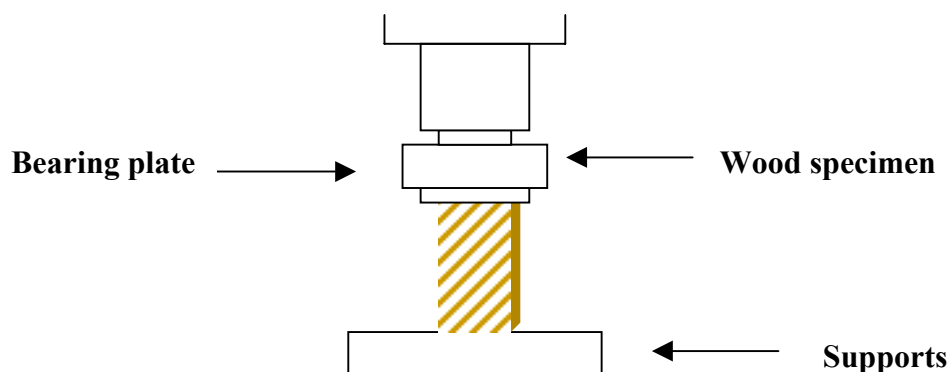

Figure A-1 Compression-Parallel-to Grain Test

- **Compression Failures**

Compression failure shall be classified according to the appearance of the fractured surface (shown in Figure A-2)

1) *Crushing*: This term shall be used when the plane of rupture is approximately horizontal.

2) *Shearing*: This term shall be used when the plane rupture makes an angle of more than 45 deg with the top of the specimen.

3) *Wedge Split*: The direction of the split, that is whether radial or tangential, shall be noted.

4) *Splitting*: This type of failure usually occurs in specimens having internal defects prior to test culling the specimen.

5) *Compression and Shearing Parallel to Grain*: This failure usually occurs in cross grained pieces and shall be the basis for culling the specimen.

6) *Brooming or End-Rolling*: This type of failure is usually associated with either an excess moisture content at the ends of the specimen, improper cutting of the specimen, or both. This is not an acceptable type of failure and usually is associated with a reduced load. Consideration should be given to remedial conditions when this type of failure is observed.

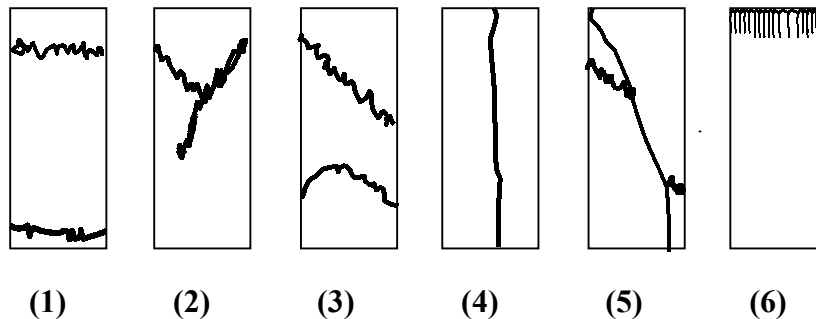

Figure A-2 Types of failures in compression

- **Specific Gravity and Moisture Content**

See A-2 and A-3

- **Calculation of Results**

The results is given in term of Ultimate stress in compression parallel to grain, σ_c and can be expressed as:

$$\sigma_c \text{ (MPa)} = \frac{P_{\max}}{a \times b}$$

Where P_{\max} = Maximum load (N or kg)
 $a \times b$ = Surface area (mm² or cm²)

A-5. Compression Perpendicular to Grain

- **Size of Specimen**

The compression-parallel-to-grain tests shall be made on nominal 20 by 20 by 60 mm specimens. The actual cross-section dimensions and the length shall be measured. Special care shall be used in preparing the compression-parallel to grain test specimens to ensure that the end grain surface will be parallel to each other and at right angles to the longitudinal. Measurements of test specimens shall be measured by caliper (read 2 position decimal).

- **Loading Method**

The load shall be applied through a metal bearing plate 20 mm in width, placed across the upper surface of the specimen at equal distances from the ends and at right angles to the length (Figure A-3).

The specimens shall be placed so that the load will be applied through the bearing plate to a radial (quarter-sawed) surface.

The load shall be applied continuously throughout the test at a rate of motion of the movable crosshead of 0.305 mm/min.

Load-compression curve shall be taken for all specimens up to 2.5 mm compression, after which the test shall be discontinued.

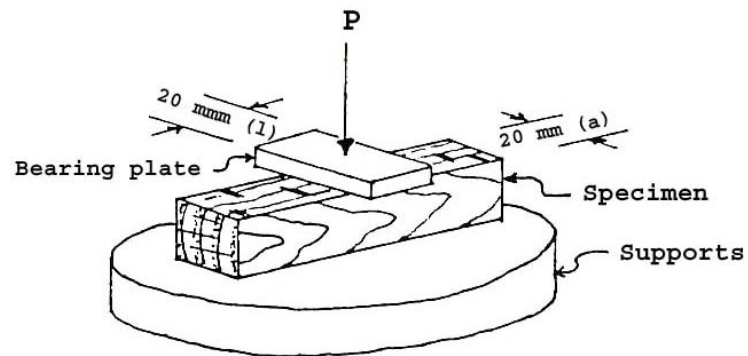

Figure A-3 Compression-Perpendicular-to-Grain Test

- **Specific Gravity and Moisture Content**

See A-2 and A-3

- **Calculation of Results**

Load (y-axis) are plotted against deformation (x-axis) (FigureA-4) and $\sigma_{P.L.}$ can be expressed:

$$\sigma_{P.L.} = \frac{P_{P.L.}}{A}$$

Where

- $\sigma_{P.L.}$ = Fiber stress at proportional limit (Mpa)
- = Conventional strength in compression perpendicular to grain
- $P_{P.L.}$ = Load at proportional limit (N or kg)
- A = Width of specimen (a) \times Width of metal bearing plate (l)

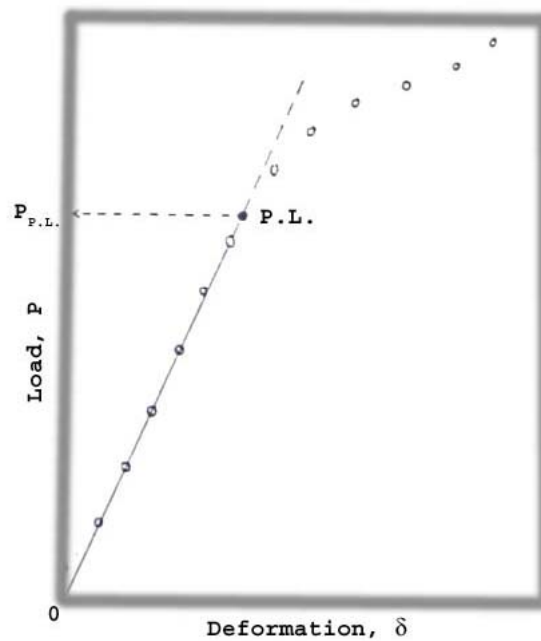

Figure A-4 Graph showing relation between load and deformation

A-6. Shearing Stress Parallel to Grain

- **Size of Specimen**

The shear parallel to grain tests shall be made on 20 by 20 by 20 mm (followed to BS 373 and ISO 3346) (see Figure A-5)

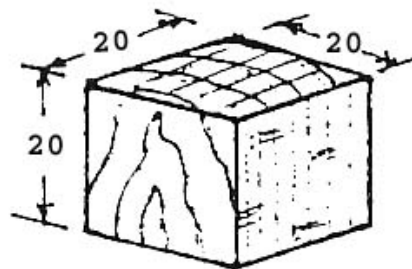

Figure A-5 Shear Test Specimen

- **Loading Method**

Use a shear tool similar to that illustrated in Figure A-6 providing a 3.175 mm (1/8 in) offset between the inner edge of the supporting surface and the plane along which the failure occur. Apply the load to, and support the specimen on end grain surfaces. Take care in placing the specimen in the shear tool to see that the crossbar adjusted so that the edges of the specimen are vertical and the end rests evenly on the support over the contact area (see Figure A-7). Observe the maximum load only.

The load shall be applied continuously throughout the test at a rate of motion of the movable crosshead of 0.6 mm/min.

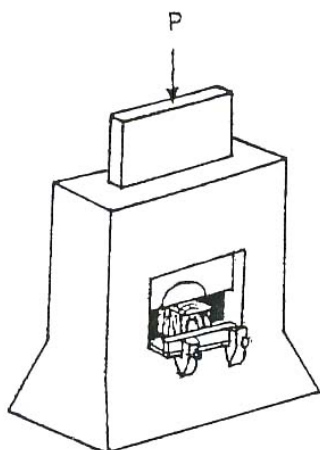

Figure A-6 Shear Test

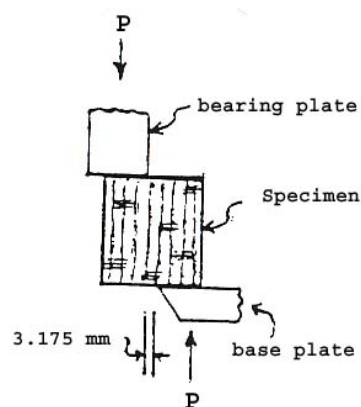

Figure A-7 Shear Test Showing Method of Load Application Through Adjustable Seat to Provide Uniform Later Distribution of Load

- **Specific Gravity and Moisture Content**

See A-2 and A-3

- **Calculation of Results**

The results is given in term of Ultimate shearing stress parallel to grain, τ and can be expressed as:

$$\tau \text{ (Mpa)} = \frac{P_{\max}}{A_s}$$

Where P_{\max} = Maximum load (N or kg)
 A_s = Surface area (mm^2 or cm^2)

A-7. Strength and Stiffness in Static bending

- **Size of specimens**

The static bending tests shall be made on nominal 20 by 20 by 300 mm specimens. The actual height and width at the center, and the length shall be measured.

- **Loading Method**

Center loading and span length of 280 mm shall be used. Both supporting knife edges shall be provide with bearing plates and rollers of such thickness that the distance from the point of support to the central plane is not greater than the depth of specimen. The knife edges shall be adjustable laterally to permit adjustment for slight twist or warp in the specimen. A bearing block having a radius of curvature of 25 mm for a chord length of not less than 2 in. (50 mm) shall be used.

The load and deflection of the first failure, the maximum load, and points of sudden change shall be read and show on the curve sheet although they may not occur at one of the regular load or deflection increments.

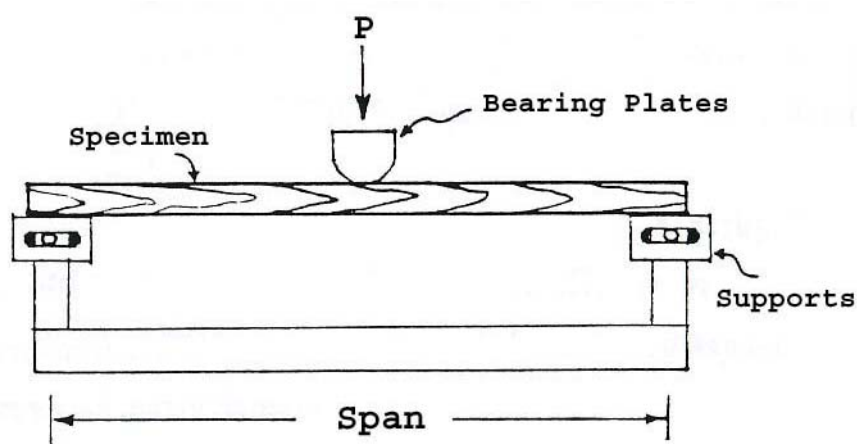
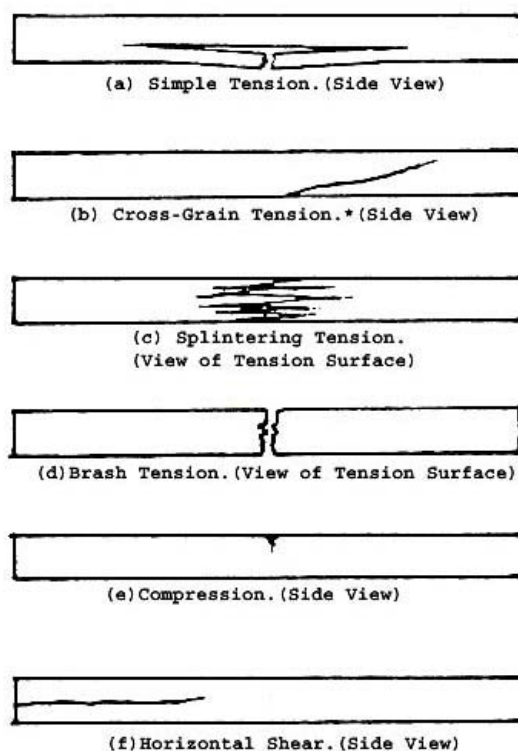

Figure A-8 Static Bending Test

- **Description of Static Bending Failures**

Static bending (flexural) failures shall be classified according to the appearance of the fractured surface and the manner in which the failure develops (Figure A-9). The fractured surfaces may be roughly divided into “brash” and “fibrous” the term “brash” indicating abrupt failure and the term “fibrous” indicating a fracture showing splinters.



*The term “cross grain” shall be considered to include all deviation of grain from the direction of the longitudinal axis or longitudinal edges of the specimen. It should be noted that spiral grain may be present even to a serious extent without being evident from a casual observation.

Figure A-9 Type of Failures in Static Bending

- **Specific Gravity and Moisture content**

See A-2 and A-3

- **Calculation of Results**

1) *Modulus of rupture (MOR)*-- Reflects the maximum load carrying of a member in bending and is proportional to maximum moment borne by the specimen. Modulus of rupture is an accepted criterion of strength.

$$\text{MOR} = \frac{3P_{\max}L}{2bd^2}$$

2) *Modulus of elasticity (MOE)*—Deformations produced by low stress are completely recoverable after loads are removed. When loaded to high stress levels, plastic deformation or failure occurs.

$$\text{MOE} = \frac{3P_{pl}L^3}{4\delta_{pl}bd^3}$$

3) *Work to maximum load (W)*—Ability to absorb shock with some permanent deformation and more or less injury to a specimen. Work to maximum load is measure of the combined strength and toughness of wood under bending stresses.

Where

P	= Load (N or kg)
P _{max}	= Maximum load (N or kg)
P _{pl}	= Load at proportional limit (P.L.)
δ	= Deformation (mm or cm)
δ _{pl}	= Deformation at proportional limit (P.L.)
b	= Width (mm or cm)
d	= Breadth (mm or cm)
L	= Length of specimen between span (mm or cm)

A-8. Hardness

- **Size of specimens**

The hardness test shall be made on 50 by 50 by 50-mm specimens. The actual cross-section dimensions and length shall be measured.

- **Loading Method**

Place the specimen in the hardness tool and use the ball test with a “ball” 0.44 in (11.3mm) in diameter for determining hardness (Figure A-10). Record the load at which the “ball” has penetrated to one half its diameter (5.64 mm), as determined by an electric circuit indicator or by the tightening of the collar against the specimen.

The load shall be applied continuously throughout the test at a rate of motion of the movable crosshead of 6 mm/min.

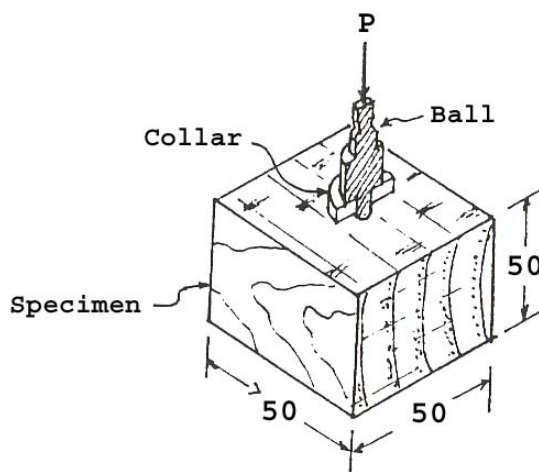

Figure A-10 Hardness Test

- **Specific Gravity and Moisture content**

See A-2 and A-3

- **Calculation of Results**

The hardness will be calculated by:

$$H_m = KP$$

Where

Hm = Hardness at the moisture content (m) during testing

P = Maximum load (N or kg)

K = Coefficient

= 1 if the ball test has penetrated to specimen 5.64-mm depth

= 4/3 if the ball test has penetrated to specimen 2.82-mm depth